

Product description

Premium Preheat 500 A is an air-air heat recovery ventilation heat pump which is equipped with the following: An aluminum counter current heat exchanger, a heat pump with cooling function, pre-heater integrated in the heat pump, supply and extract air fans, F7 supply air filter, M4 extract air filter, and complete Optima 301 automatics with a control panel.

Premium Preheat 500 A can be delivered with the following accessories:

- Electrical reheater for Ø200 mm duct



Application

Premium Preheat 500 A is suitable in dwellings where a combination of heat recovery ventilation and supply of comfort heating or cooling with the supply air is desired.

Before the fresh air is drawn into the house, heat is supplied to it in the counter current heat exchanger - heat recovered from the extract air.

Then additional heat is supplied to the supply air by the heat pump and thereby it contributes to the home heating. If it is desired that cooling is supplied to the air instead, this is also possible.

The supply air filter ensures that dirt and pollen is not brought into the house.

Premium Preheat 500 A can deliver an air volume of up to appr. 600 m³/h at an external pressure of 100 Pa.

Types

Premium Preheat 500 A is available in a right- or left-handed version

Dimensions

Premium Preheat 500 A (right-handed)
Dimensions in mm.

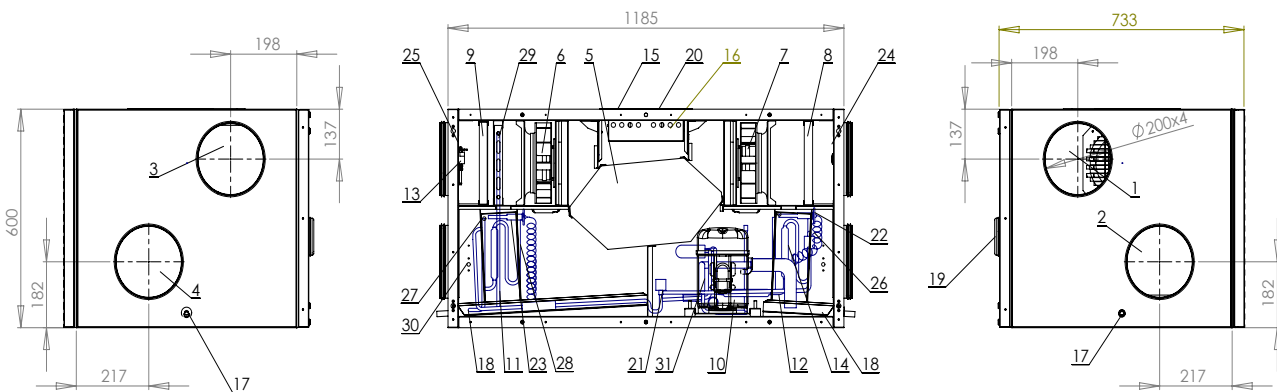

- | | | | |
|--------------------------------|--------------------------|--|-------------------------------|
| 01. Fresh air Ø200 | 09. Supply air filter | 17. Condensate drain Ø15 | 24. Sensor, extract air |
| 02. Exhaust air Ø200 | 10. Compressor | 18. Condensation tray | 25. Sensor, fresh air |
| 03. Extract air Ø200 | 11. Evaporator | 19. Supply air connection Ø100 at the back | 26. Sensor, supply air |
| 04. Supply air Ø200 | 12. Condenser | 20. Switch | 27. Sensor, evaporator |
| 05. Counter current heat exch. | 13. High pressure switch | 21. Magnetic valve, defrosting | 28. Sensor, before evaporator |
| 06. Supply air fan | 14. Process valve | 22. Thermo valve, condenser | 29. Preheater |
| 07. Extract air fan | 15. Cable entry | 23. Thermo valve, evaporator | 30. Sensor, exhaust air |
| 08. Extract air filter | 16. Electrical box | | 31. Four ways valve |



Technical data

Electrical connection without electrical reheater
1 x 230 V + N + PE, 10 A, 50 Hz

Electrical connection with electrical reheater
Max. 2.2 kW
1 x 230 V + N + PE, 16 A, 50 Hz

Fans with direct drive motor
R3G 220

Motor
EC motor with integrated electronics

Isolation class, fans
B

Protection class, fans
IP 44

Fan speed (max. per fan)
3560 rpm

Power consumption (max. per fan)
150 W

Current consumption (max. per fan)
1.10 A

Fan speed control
The fans can be adjusted individually in 3 different speeds

The working area of the heat pump
-15°/+35°C

Compressor
NT 6220 GK

Min. air volume:
230 m³/h

Power consumption (max., heat pump)
657 W

Current consumption (max., heat pump)
2.8 A

Heating perform. / COP @ 300 m³/h / 2°C fresh air temp.
3410 W / 5,19

Cooling cap. @ 26°C supply air temp. / 24°C extract air temp.
1612 W

Refrigerant / filling
R407c / 1020 g

Automatics

Premium Preheat 500 A is delivered with complete Optima 301 automatics and a control panel with a display showing the operation mode of the unit and on which the settings are easy to change.

Control panel

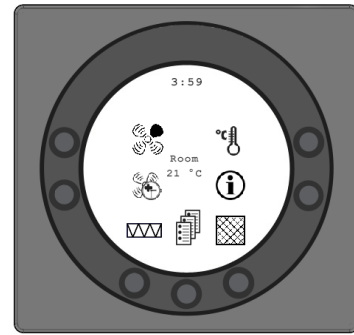



 **Speed**
Here the fan speed is adjustable in steps 0-1-2-3-4.

 **Extended operation**
Here the timer to extended operation can be set between 0 to 9 hours.

 **Reheater**
Here you can switch on and off the supplementary reheater.

 **Main menu**
Here you can enter the main menu, in which the submenus are available.

 **Filter**
Here you can reset the filter alarm.

 **Information**
Here you can get a good overview of the current operating condition of the unit.

 **Temperature**
Here you can set the room temperature.

Sound data

Measuring point	1 m in front of the unit			Extract duct			Supply duct		
	1	2	3	1	2	3	1	2	3
Air volume									
	Lp dB			Lwu dB			Lwi dB		
63 Hz	50	52	54	85	94	99	92	95	97
125 Hz	51	51	56	76	89	96	76	89	95
250 Hz	43	46	51	70	81	86	71	85	92
500 Hz	31	37	45	59	79	88	61	83	90
1000 Hz	24	36	40	57	73	81	57	72	83
2000 Hz	-	30	35	52	64	74	57	68	77
4000 Hz	-	21	30	46	60	66	49	52	63
8000 Hz	-	-	24	39	58	63	43	43	51
Sum (A-weighted)	Lp dB(A)			Lwu dB(A)			Lwi dB(A)		
	40	44	49	66	80	88	69	83	90

1. Measured at 40% of max. speed with compressor on: 200 m³/h
2. Measured at 70% of max. speed with compressor on: 360 m³/h
3. Measured at 100% of max. speed with compressor on: 570 m³/h

Construction

Size

(h x l x d) excl. connecting pieces:
600 x 1185 x 733 mm

Cabinet construction

Sandwich construction consisting of hot galvanized plate with 30 mm insulation. Powder coated white RAL 9010.

Duct connection

Ø200 mm (male end) with rubber sealing ring
Ø100 mm (male end) supply air connection pieces (pointing backwards)

Front cover

Right and left cover with snap locks for filter service

Counter current heat exchanger

Aluminium

Condensation trays

Stainless steel

Condensate drain

Stainless steel Ø15 mm (exterior)

Supply air filter

F7

Extract air filter

M4

Weight

131 kg

Flow diagram

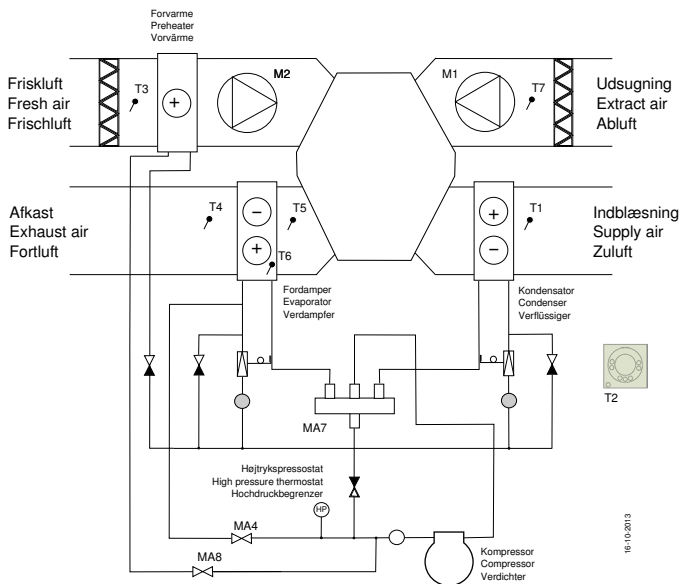

Sensors:

- T1: Supply air
- T2: Room
- T3: Fresh air
- T4: Exhaust air
- T5: Before the evaporator
- T6: Evaporator
- T7: Extract air

Magnetic valves:

- MA4: Defrosting
- MA7: Heating/cooling
- MA8: Preheater

Capacity

The capacity of Premium Preheat 500 A varies with air volume and the outdoor air temperature.

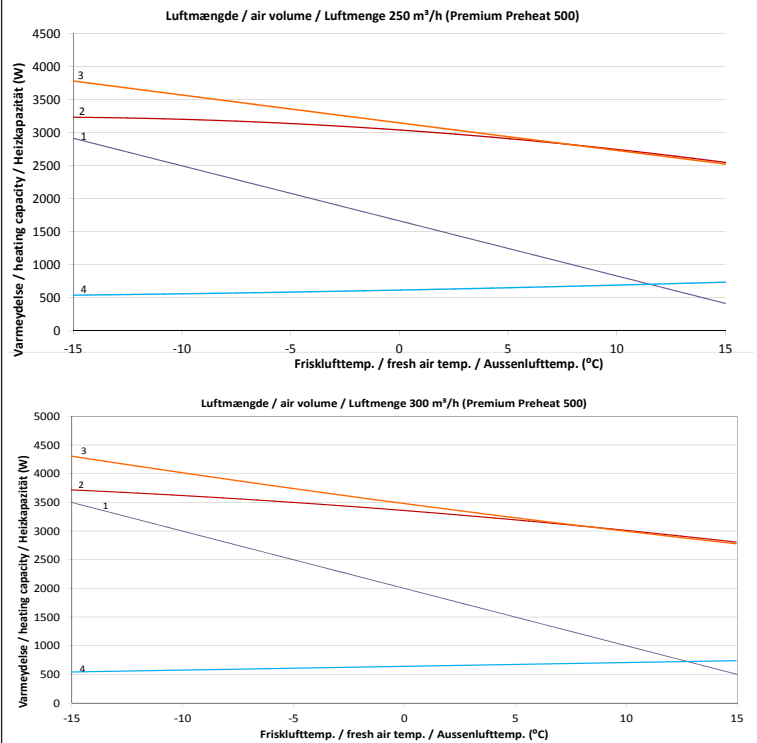

1. Energy consumption for heating supply air from outdoor air temperature to a room temperature of 20°C.
2. Total heating capacity of the unit with preheater OFF.
3. Total heating capacity of the unit with preheater ON.
4. Power consumption with the compressor running.

Cooling capacity:

With an outdoor air temperature of 26°C, relative humidity of 50% and max. air volume, the total cooling capacity is 1612 W.

Capacity

Air volume:

The capacity lines are based on an average of the supply and extract mass flow in a unit.

The black line in the chart indicates a total power consumption for both fans and the control of 1620 J/m³ (PHI).

The curve shows the average external pressure, which is available at a given air volume.

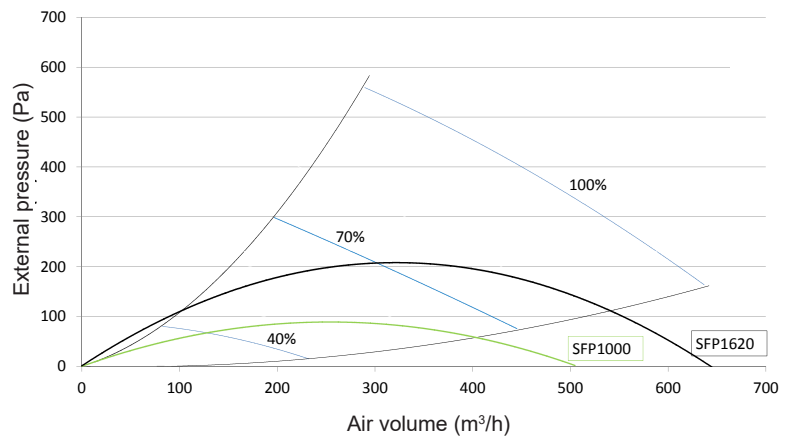

Total power consumption

For both fans and control.

- 1 = 100 %
- 2 = 70 %
- 4 = 40 %

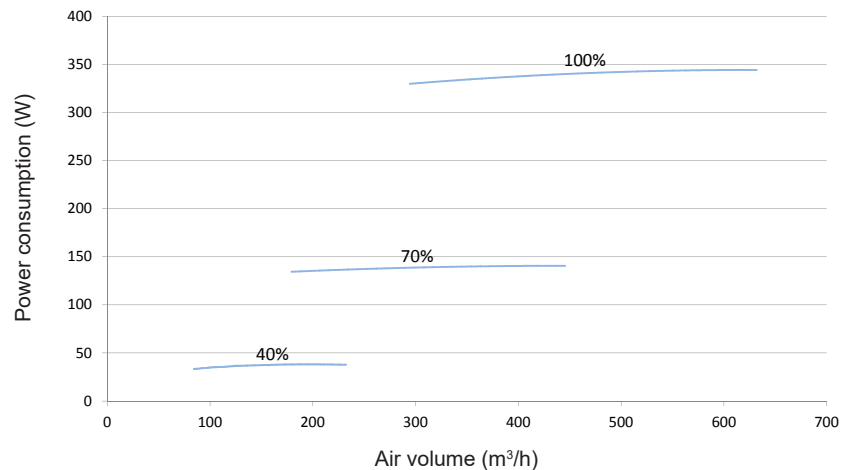

Heat recovery rate

Heat recovery rate, mass flow $m_{in} = m_{out}$

Icing of the heat exchanger at low outdoor air temperatures has been left out of account.

- 01. Outdoor temp.: -12°C
RH: 50%
- 02. Outdoor temp.: 4°C
RH: 50%

