

# QUICK GUIDE



## GENVEX CONNECT

Remote control/monitoring of  
Genvex unit via app

# INSTRUCTIONS

1. Follow the electrical diagrams for OPT251 or OPT260 to connect the Internet Gateway to the Genvex Optima controls. (OPT251: Gateway is connected directly to the display. OPT260: Gateway is connected directly to the Modbus output on the PCB).
2. Connect the Internet Gateway to the internet/router via the RJ45 connector in the Gateway. (Genvex recommends a wired connection).
3. Service menu is set via the control panel (OPT251) or GenLog (OPT260).
  - Service menu point 30: Modbus mode is set to 2 (19200 baud rate).
  - Service menu point 31: Modbus address is set to 1.
  - Note that the Modbus communication will disappear while the OPT260 PCB is being programmed via GenLog. The Modbus connection will re-establish once the programming cable has been removed.
4. Download the Genvex Connect app from App Store or Google Play.
5. Start the Genvex Connect app and select the connection.
6. Select the function “add ID” if you are setting up a connection to an Internet Gateway without being on the same network as the Internet Gateway (the 12-digit ID number is found on a label on the Gateway box itself). If the app device is found on the same network as the Internet Gateway, the ID number will be automatically identified and shown in the display.
7. Set up the user by providing an email address (the password will be auto-generated and sent to the email address). The first user who sets themselves up on the Internet Gateway will be the “owner”. Other users who require access to the same Genvex Connect system will need to log in via the app with the “owner’s” email address and password.
8. There is now access to the Genvex Connect system, which includes the opportunity to change the fan speed, raise/lower the comfort temperature and monitor the operating mode on the ventilation unit.

# ELECTRICAL DIAGRAM - OPT251

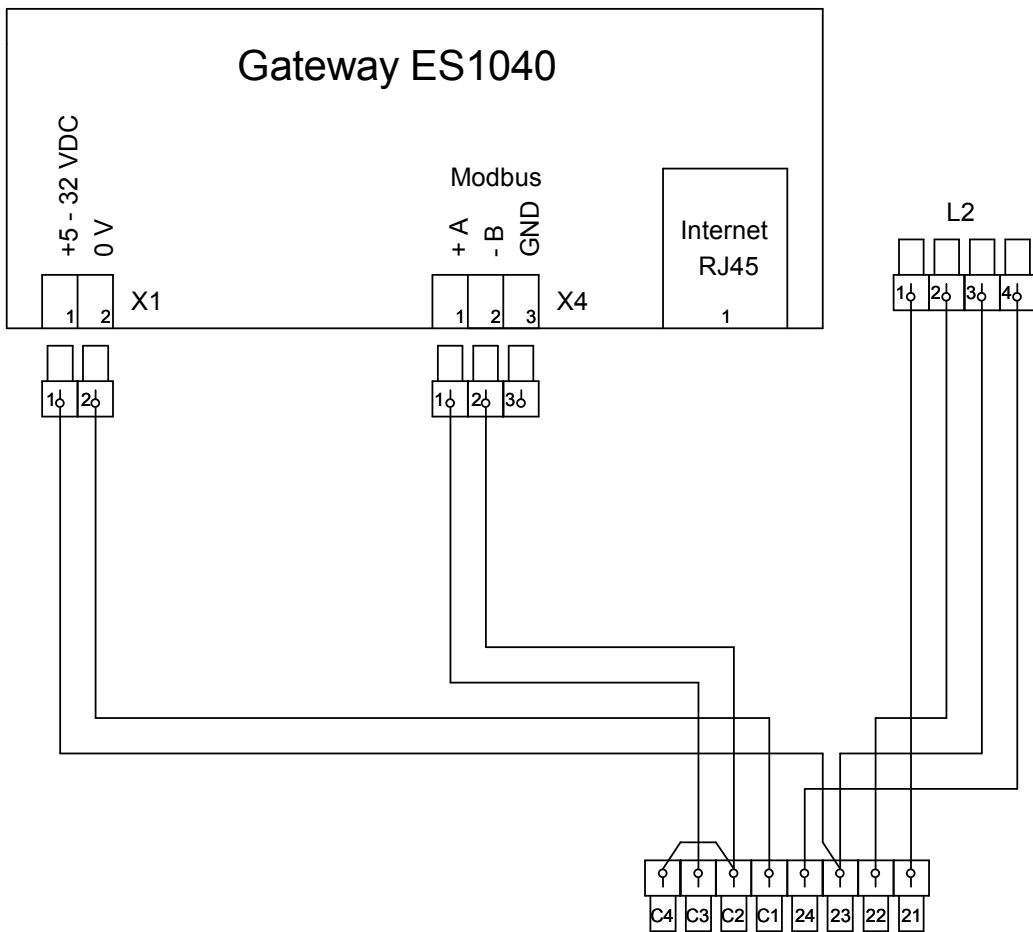
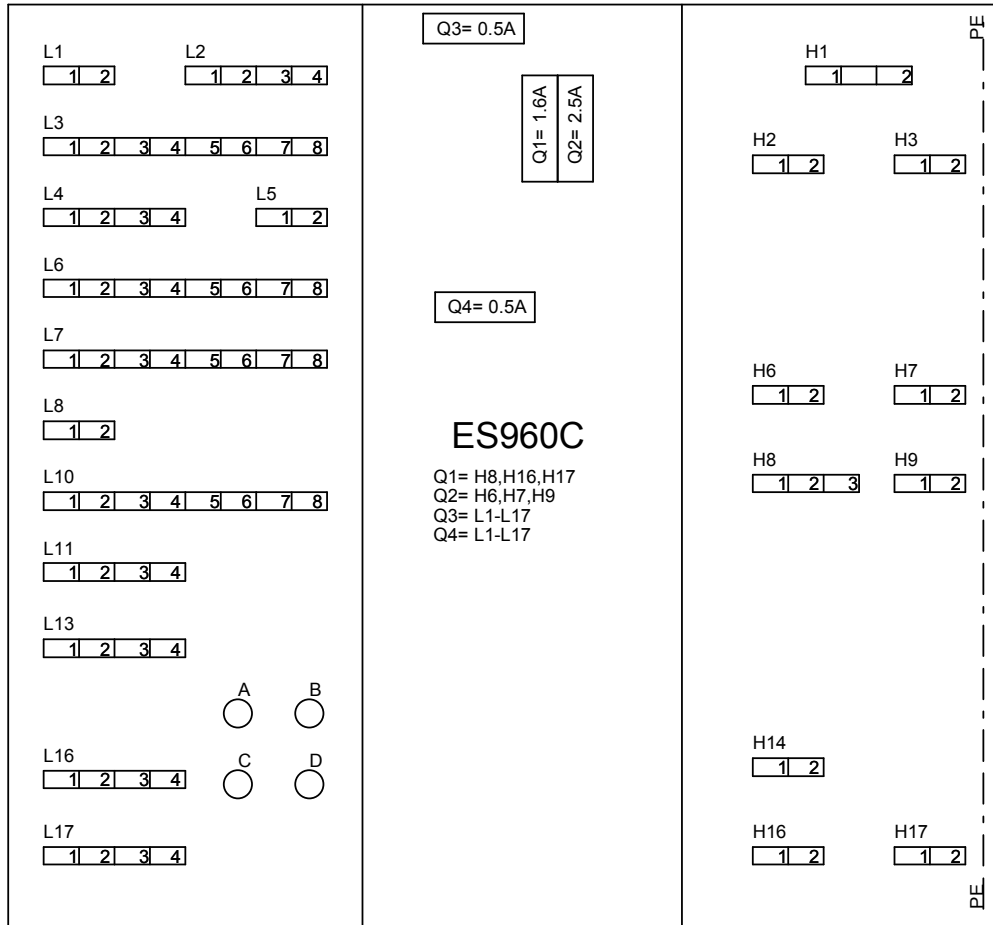

OPTIMA DESIGN

# ELECTRICAL DIAGRAM - OPT260

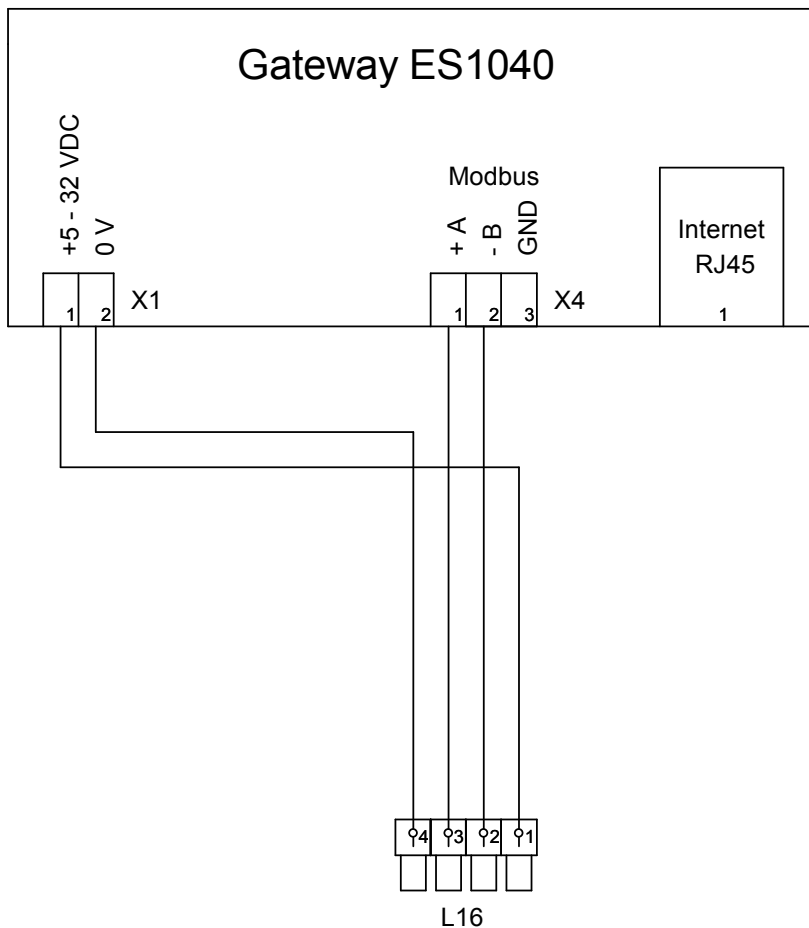
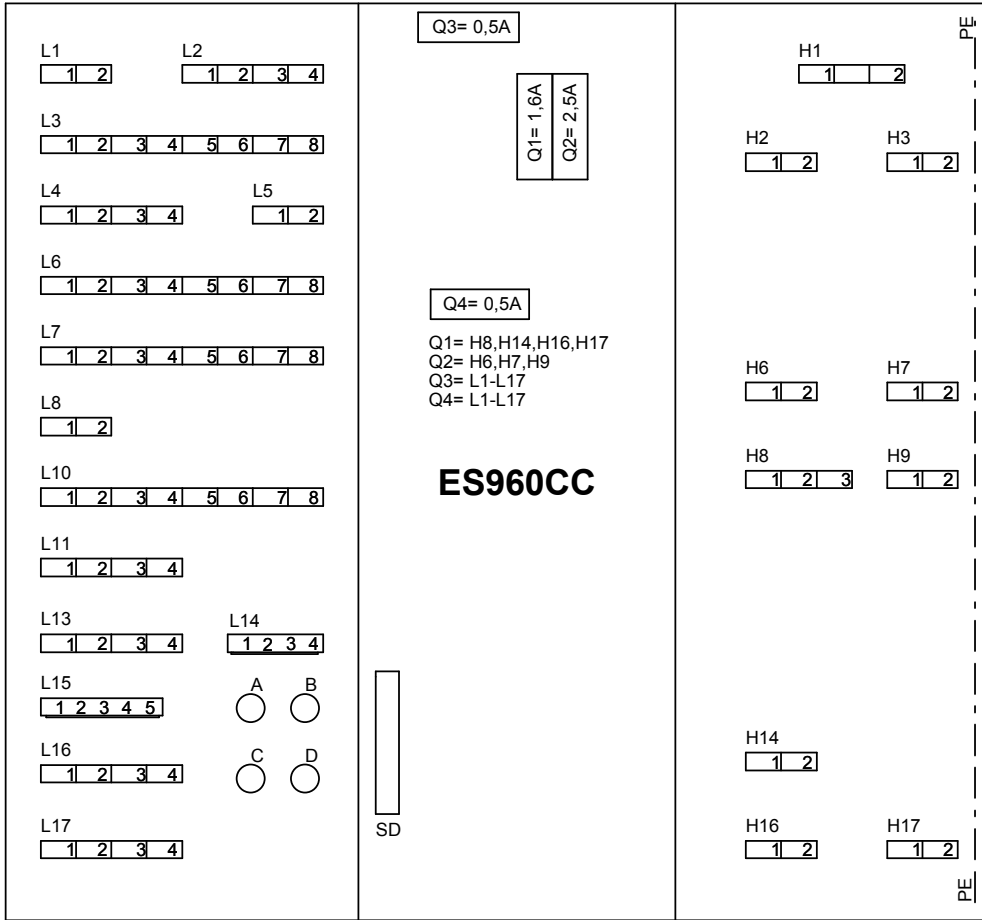

# THE AIR WE BREATHE

All  
Genvex  
systems are  
rated with  
energy label

A

The original Genvex units are assembled by skilled and experienced technicians and have a lifetime that in many cases is measured in decades. The units are approved by all applicable standards and are easy to operate and service. Last – but not least – all Genvex systems are developed with focus on compact dimensions and ease of installation and can be integrated discreetly in all types of homes.

We are part of the NIBE Group – a family of companies that specialize in supplying hot water, heating and home comfort to homeowners worldwide.



## Genvex – The original Danish Ventilation System

Genvex is a genuine Danish original. We invented the ventilation system more than 40 years ago, and we are still ahead of the pack when it comes to development and production of the strongest and most durable ventilation system.

Our unit is working in thousands of homes providing fresh clean air – free of pollen, dust and harmful particles. This helps to strengthen the health of the house and to make the indoor environment healthy and comfortable for lots of families. At the same time, our system is an important element when it comes to saving energy in homes and in society as a whole – in fact you can recover up to 95% of the heat energy with a Genvex system.

Please visit [www.genvex.com](http://www.genvex.com) to see a list of our distributors

08:401-1901

