

INSTALLATION AND OPERATION INSTRUCTIONS

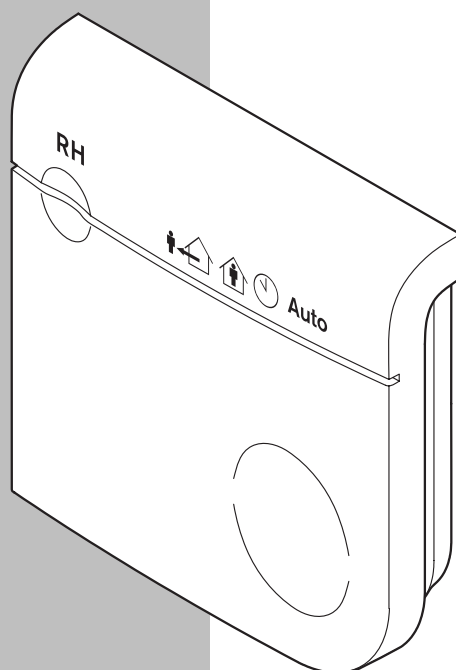

A+ RH SENSOR MODULE

INSTALLATION

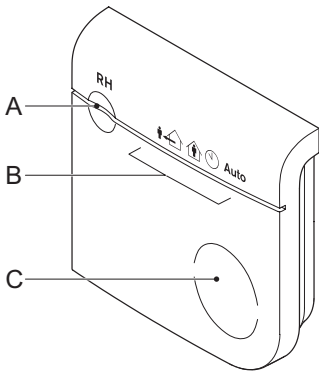

- A: Status LED
- B: Mode LEDs
- C: Touch button

1 About this manual

1.1 About the device

The sensor module is a user control and humidity sensor for a ventilation system. The device communicates information about ventilation speed request and system status via wireless communications with the central control device.

1.2 How to use this manual

This manual is intended as a reference book by which qualified installers can install the sensor module (henceforth called “device”) and users can use the device for its intended purpose. Make sure you have read and understood the manual before you install and/or use the device.

1.3 Original instructions

The original instructions for this manual have been written in English. Other language versions of this manual are a translation of the original instructions.

1.4 Admonitions



NOTE

‘Note’ is used to highlight additional information.

2 Safety

2.1 Directives

The device meets the following EC directives:

- EMC directive: 2004/108/EC
- Low voltage directive: 2006/95/EC
- RTTE directive: 1999/5/EC
- RoHS directive: 2002/95/EC
- WEEE directive: 2002/96/EC

2.2 Signs on the unit



CE marking of conformity



Use of the device may not be legal in every member state.



Dispose according to European Community Directive 2002/96/EC (WEEE).

2.3 General safety instructions

The device is designed for indoor use only. Do not expose the device to rain or moisture, to avoid short circuit. Short circuit may cause fire or electric shock hazard. Operate the device between 0°C and 40°C. For cleaning of the device use a soft damp cloth only. Never use any abrasive or chemical cleaner.

Do not paint the device.

3 Description

3.1 Intended use

The device is designed for following purposes:

- 1 To set the speed level of ventilation through the fan speed, based on user input or measured humidity level.
- 2 To set parameters for the ventilation control.
Every other or further use is not in conformance with the intended use.

3.2 Working principle

The device communicates with the control device using wireless communications, in order to control the ventilation. Via the button and LEDs you can read and set the mode of control that the ventilation system currently is in. When in Auto mode, the device requests the level of ventilation based on the relative humidity (RH).

3.2.1 Ventilation speeds and modes

The ventilation system runs in one of the following modes. In each of these modes, the control device sets the ventilation system to a configured level of ventilation.

- Away mode: Low fan speed
- Home mode: Medium fan speed
- Timer mode: High fan speed, for a restricted duration.
- Auto mode: Auto Between Low fan speed and High fan speed, based on measured values.

The control device drives the fan based on the highest of values sent by the bound wireless sensor(s).

When you start the timer mode from this device, the ventilation will be active for 30 minutes.

3.2.2 RH measurement

The device continuously measures the relative humidity (RH) in the air. When in Auto mode, the device controls the ventilation based on the course of the measured values: the ventilation starts when the humidity gets above a certain level, or for some time when the humidity suddenly increases.



NOTE

The device stores the configured fan speed values in the control device, and requests them from there.

The device stores the RH setpoint itself, and does not communicate this with any other device.

3.3 Visual signals

	Status LED	Mode LEDs				
Startup						Auto
System status	White Continuous	On	On	On	On	On
System status	Green	Continuous Status OK				
		flash Com. error 1				
		flashes Filter dirty 2				
	Red	flashes Fan error 3				
		flashes RH sensor error 4				
		flashes Low battery 5				
Selecting						
Away mode			•			
Home mode	Off			•		
Timer mode					•	
Auto mode						•



NOTE

When setting the fan speeds, make sure that the medium fan speed is between the low fan speed and the high fan speed.

4 Operation

4.1 Show status

- Tap the button.
The Status LED and Mode LEDs show the status of the system.

4.2 Set mode

From the status screen:

- Tap the button.
The mode LEDs show the next selection.
- If needed, tap the button within 2 seconds.
Repeat until the selection shows the required mode.
- Wait 2 seconds. The device applies the requested mode.
The Status LED and Mode LEDs show the status of the system.

5 Installation

5.1 Preparation



NOTE

Do not place the device in a metal casing.

- Press the clip and pull the top section from the bottom section.

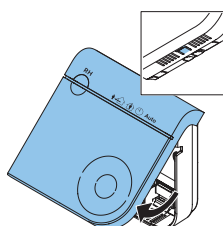

When you do not place the device on a flush mounted wall box:

When the wall material needs preparation, use the mounting plate as a template.

5.2 Commissioning

- Place the batteries.
All LEDs are ON for 3 seconds.
- Wait until the status LED shows the binding mode.
If the device shows another indication, the device is already bound. See 6.2 on how to bind the device again.
- Tap the button. The device will try to bind to the control device, and shows the result on the status LED. When the communication failed, make sure that the control device is in binding mode, and retry.

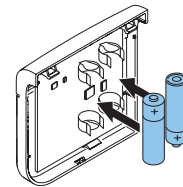

5.3 Installation procedure

- Place the bottom section of the device.
- Fasten the bottom section using the screws.

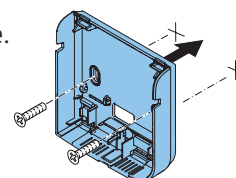

5.4 Close top section

- Place the top section of the device onto the bottom section.
 - Place the clips.
 - Close and press until it clicks.

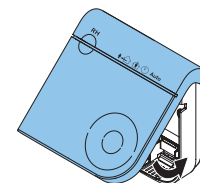

6 Configuration

	Status LED	Mode LEDs					
						Auto	
Step 1	Configuration						
	Low fan speed	•					
	Medium fan speed	Off	•				
	High fan speed			•			
	Binding					•	
Step 2	Value	Blue/red Low fan speed	Off	10%	20%	30%	40%
		Blue/green Medium fan speed	30%	40%	50%	60%	70%
		Red/green/blue High fan speed	60%	70%	80%	90%	100%
		Red/green Binding					

6.1 Configure settings

From the status screen (see 4.1):

- Tap the button.
The mode LEDs show the next selection.
- If needed, tap the button within 2 seconds. Repeat until the selection shows the item to configure.

- 3 Press and hold the button until the Status LED starts flashing white.
- 4 Release the button.
The status LED shows the item selected, and the Mode LEDs show its current value.
- 5 If needed, tap the button within 10 seconds, until the Mode LEDs show the value to set.

i NOTE

When setting the fan speeds, make sure that the medium fan speed is between the low fan speed and the high fan speed.

- 6 Wait 10 seconds.
The device applies the configured value.
The Status LED and Mode LEDs show the status of the system.

6.2 Bind the device again

From the status screen:

- 1 Tap the button. The mode LEDs show the next selection.
- 2 If needed, tap the button within 2 seconds, until the selection shows the 4th LED.
- 3 Press and hold the button until the Status LED starts flashing white.
- 4 Release the button. The status LED shows the binding mode.
- 5 Tap the button.
The device will try to bind to the control device.
It shows the result on the status LED.

6.3 Perform a factory reset

From the status screen:

- 1 Tap the button. The mode LEDs show the next selection.
- 2 If needed, tap the button within 2 seconds, until the selection shows the 4th LED.
- 3 Press and hold the button until the Status LED starts flashing white.
- 4 Release the button.
The status LED shows the binding mode.
- 5 Press and hold the button for 10 seconds.
The status LED shows white.
- 6 Release the button. The device releases its binding and restarts.
The device will return to the binding mode.

7 Replacing the battery

See 5.1, 5.2 and 5.4 for visual instructions.

8 Technical data

8.1 Dimensions

Overall dimensions (h x w x d): 100 x 100 X 25 mm
Weight: ± 125g

8.2 Ambient conditions

Operating Temperature Range: 0 to 40 °C
Shipping & Storage
Temperature Range: -20 to 55°C
Relative Humidity: 0 - 90%, non-condensing
Ingress protection (IEC60529): IP30

8.3 Battery specification

Type: AA battery, 2x
Battery lifetime: 2 years

8.4 Wireless connection specifications

Communication frequency: 868.3 MHz
Output power: at least 0 dBm.
You are not allowed to use the device outside of Europe.

8.5 RH measurement specifications

Measurement range: 0 - 100 % RH
Measurement accuracy
• at 11-89%RH: 3% RH
• at 0-10% and 90-100%: 7% RH
Measurement resolution: 1%RH
Measurement stability: 1.5%RH over 5 years

