

INSTALLATION AND OPERATION INSTRUCTIONS

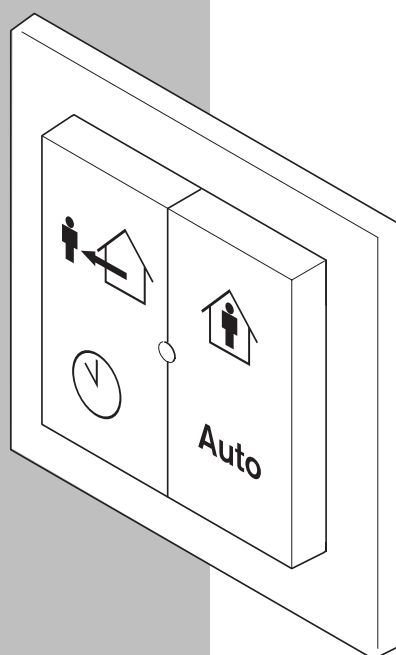

A+ USER INTERFACE MODULE

INSTALLATION

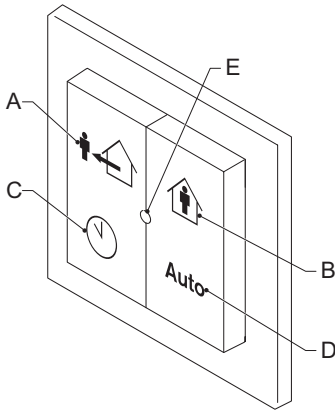

- A: Away button
- B: Home button
- C: Timer button
- D: Auto button
- E: Status LED

1. About this manual

1.1. About the device

The User interface module is a user control for a ventilation system. The device communicates information via wireless communications with the central control device.

1.2. How to use this manual

Make sure you have read and understood the manual before you install and/or use the device.

1.3. Original instructions

The original instructions for this manual have been written in English. Other language versions of this manual are a translation of the original instructions.

1.4. Admonitions

NOTE

'Note' is used to highlight additional information.



2. Safety

2.1. Directives

The device meets the following EC directives:

- EMC directive: 2004/108/EC
- Low voltage directive: 2006/95/EC
- RTTE directive: 1999/5/EC
- RoHS directive: 2002/95/EC
- WEEE directive: 2002/96/EC

2.2. Signs on the unit

-  CE marking of conformity
Use of the device may not be legal in every member state.
-  Dispose according to European Community Directive 2002/96/EC (WEEE).

2.3. General safety instructions

The device is designed for indoor use only. Do not expose the device to rain or moisture, to avoid short circuit. Short circuit may cause fire or electric shock hazard. Operate the device between 0°C and 40°C. For cleaning of the device use a soft damp cloth only. Never use any abrasive or chemical cleaner.

Do not paint the device.

3. Description

3.1. Intended use

The device is designed for the purpose to set the level of ventilation through the fan speed, based on user input. Every other or further use is not in conformance with the intended use.



3.2. Working principle

The device communicates with the control device using wireless communications, in order to control the ventilation.

When you press a button, the device sends this information to the ventilation system. The ventilation system processes this request and sends the resulting status back to the device. The device shows the resulting status on the LED.

3.2.1. Ventilation speeds and modes

The ventilation system runs in one of the following modes. In each of these modes, the control device sets the ventilation system to a configured level of ventilation.

- Away mode:  Low fan speed
- Home mode:  Medium fan speed
- Timer mode:  High fan speed, for a restricted duration.
- Auto mode: Auto Between Low fan speed and High fan speed, based on measured values.

The control device drives the fan based on the highest of values sent by the bound wireless sensor(s).

You can start the timer mode from this device for 30, 60 or 90 minutes.

3.3. Visual signals

	Status LED	
Startup		
Power up	Orange	flash 1
Status		
OK	Green	
Low battery	Orange	flash 1
Dirty filter	Orange	flashes 2
Fan error	Red	flashes 2
Interaction response		
Mode changed	Green	flash 1
Binding succeeded	Green	flashes 2
Communication error	Red	flash 1

4. Installation

4.1. Preparation

i NOTE
Do not place the device in a metal casing.

If not placing on a flush mounted wall box, prepare the wall:

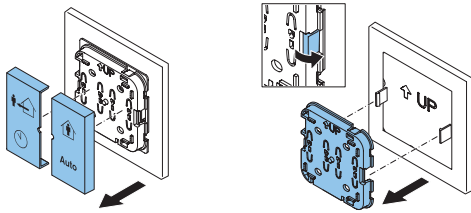

1. Pull the buttons from the unit
2. Loosen the clips and separate the unit from the mounting plate.
3. If using screws: prepare the wall, if needed. Use the mounting plate as a template.
4. If using tape:
 - a. Remove the foil from the double-sided tape.
 - b. Make sure that the surface is flat & clean.

4.2. Installation procedure

1. Place device / mounting plate
2. If using screws: fasten the mounting plate using the screws.

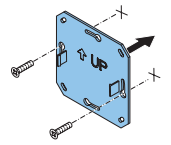

3. Place the device onto the mounting plate.

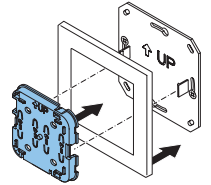

4. Place the buttons.

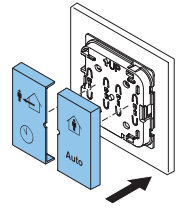

4.3. Commissioning

1. Make sure the control device is in binding mode.
2. Press and hold the two upper or two lower buttons. The device tries to bind to the control device. It shows the result on the status LED.

5. Operation

1. Press the required button.
For button C:
press 1x for 30 minutes
press 2x for 60 minutes
press 3x for 90 minutes
The device shows the result on the status LED.

6. Filter dirty reset

To reset the filter dirty message, press and hold AWAY and AUTO for at least 4 seconds.

7. Replacing the battery

(See section 4 for more visual instructions)

1. Remove the buttons from the unit.
2. Loosen the clips and separate the unit from the mounting plate.

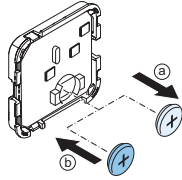

3. Replacing the battery
 - a Remove the old battery.
 - b Place the new battery.The LED shortly shows orange.
4. Place the device onto the mounting plate.
5. Place the buttons.

8. Technical data

8.1. Dimensions

Overall dimensions (h x w x d): 84 x 84 x 15 mm
Weight: ± 125g

8.2. Ambient conditions

Operating Temperature Range: 0 to 40 °C
Shipping & Storage Temperature Range: -20 to 55°C
Relative Humidity: 0 - 90%, non-condensing
Ingress protection (IEC60529): IP30

8.3. Battery specification

Type: CR2032
Battery lifetime: 6 years

8.4. Wireless connection specifications

Communication frequency: 868.3 MHz
Output power: at least 0 dBm.
You are not allowed to use the device outside of Europe.