

# OPERATING INSTRUCTIONS



## OPTIMA 301

# Table of contents

|                                                             |    |
|-------------------------------------------------------------|----|
| <b>1. Control panel</b> .....                               | 3  |
| <b>2. Mounting of the control panel</b> .....               | 3  |
| <b>3. Start-up</b> .....                                    | 4  |
| <b>4. Operating</b> .....                                   | 5  |
| 4.1 Operating and changing date in the operating menu ..... | 5  |
| 4.2 Main menu .....                                         | 6  |
| 4.3 Date and time .....                                     | 6  |
| 4.4 Calendar .....                                          | 6  |
| 4.5 User menu .....                                         | 7  |
| 4.6 Display menu .....                                      | 7  |
| 4.7 Operation info .....                                    | 9  |
| 4.8 Service menu .....                                      | 10 |
| 4.9 Schedule for defrosting .....                           | 13 |
| 4.10 Schedule for weekly programs .....                     | 14 |
| 4.11 Schedule for set points .....                          | 15 |
| <b>5. Function</b> .....                                    | 16 |
| 5.1 Control .....                                           | 16 |
| 5.2 Extra capacity .....                                    | 16 |
| 5.3 Reliability .....                                       | 16 |
| <b>6. Maintenance</b> .....                                 | 17 |
| 6.1 Alarms (error messages) .....                           | 17 |
| 6.3 Disassembly/discontinue using the unit .....            | 17 |
| <b>7. Trouble shooting</b> .....                            | 17 |
| 7.1 High pressure switch .....                              | 17 |
| 7.2 The unit is not running .....                           | 17 |
| 7.3 Air faults .....                                        | 17 |

# 1. Control panel

The control panel must be mounted on an interior wall that is located centrally in the home.

Since the control panel also functions as a room thermostat, it is important that the following are observed:

- Do not expose the control panel to direct sunlight.
- Do not mount the control panel on an outer wall.
- Do not recess the control panel in the wall.
- Do not place the control panel above a heat source.

A lamp too close to the control panel can affect the light sensor so that the control panel will not regulate the light intensity as intended.

On the front of the control panel there are 7 buttons used for operating the panel. The buttons change function depending on which menu is selected.

There is an infrared movement sensor located under the glass screen. Simply by passing your hand over the control panel you can bring up the menu for daily operating options. This function can be turned off.

The following are located at the bottom of the control panel:

- 1: SD card
- 2: Room sensor
- 3: Light sensor
- 4: Mini USB port for connection to computer

1: The removable SD card contains all the control models and versions that make the control panel compatible with older versions.

The SD card also contains all the languages, menus, help texts, symbols and collected data logs.

During the start-up procedure, the current versions are installed in the control panel so that the control can function without the SD card. However, if the SD card is not installed the help texts will not appear in the display and the data logs will not be saved.

4: In order for a computer to read the data logs, the Genvex data logger program must be installed.

# 2. Mounting of the control panel

The control panel is designed to be mounted on a level wall.

Find the location on the wall where the control panel is to be mounted and mark the screw hole. A min. of four screws must be used, the two upper screws and the two lower screws.

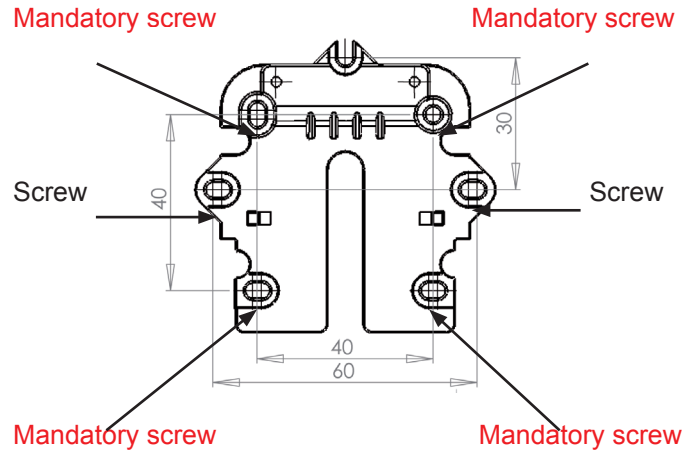

Hold the wall frame against the wall and mark the screw hole positions. Drilling of holes, hole size and the corresponding screws for attaching the panel depend on the wall material.

Place the control panel in the fixtures and tilt it in against the wall. The four support points in the corner of the display must touch the wall to keep the display stable.

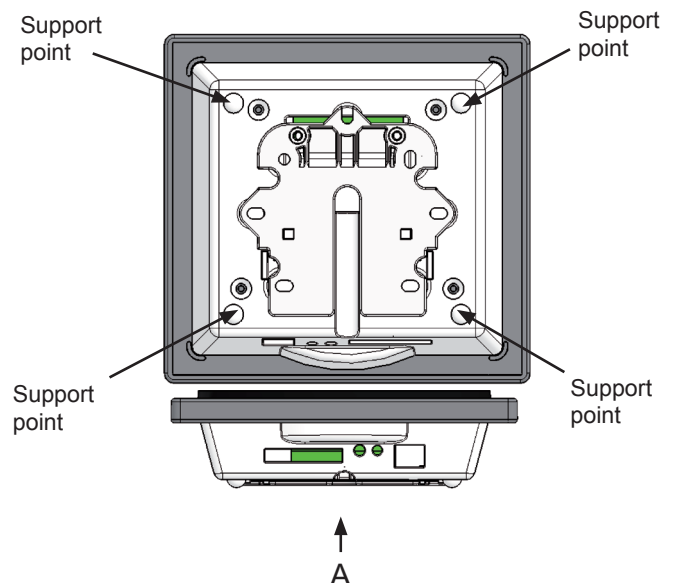

Underneath the control panel there is an access for the:  
A: Terminal block. Connection to main circuit board.

A low current cable 4 x 0.25 mm<sup>2</sup> must be attached between the unit and the control panel. 50 m is the maximum cable length. A cable length above 50 m can result in disruption.

Wiring connections to terminals 21-24:

|    |         |
|----|---------|
| 21 | Signal  |
| 22 | Signal  |
| 23 | 10 Volt |
| 24 | 0 Volt  |

**How to mount the wall bracket:**

At first, screw the fixture onto a level wall and pass the visible cable up from below.

Connect the low current cable to the terminals. Check that the cable is connected to the same numbers at both ends (between the control panel and the main circuit board in the unit) according to the electrical diagram in the installations manual.

Next clip the control panel onto the wall bracket by sliding it down from above, slightly slanting out at the bottom. Finish by pressing in at the bottom so that it sits flat against the wall.

**When dismantling:** Pull the control panel slightly out at the bottom and lift it up.

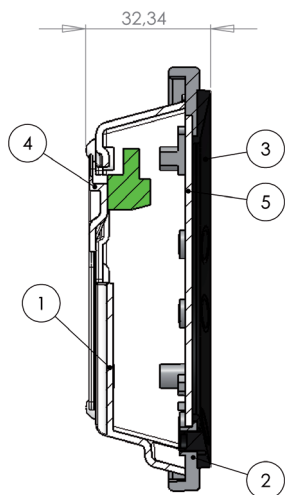

| Pos. | Description                |
|------|----------------------------|
| 1    | Panel housing              |
| 2    | Front of panel             |
| 3    | Pressure plate for display |
| 4    | Wall bracket               |
| 5    | Glass for the display      |

### 3. Start-up

The first time the system is started, the display will show: "Choose language".

Click "Next" to switch between the different languages. Press "Enter" when the desired language is shown in the display. The control panel will now upload the current program version in the selected language.

**The display will show:**

- Updating model (loading the current model)
- Wait 1.5 minutes (it takes approximately 1.5 minutes to load the current version)
- Language load (105)
- Language OK
- Menu load (84)
- Menu OK
- Icon load (405)
- Menu OK
- Reset to default
- Restarting.....
- Optima 301 UK

**Then the display will then change to:**

- Genvex logo
- Optima 301 UK
- Versionsnummer
- D (Display): 3.1
- C (Main board): 1.4

Finally, the display changes to daily operation and the system is now in operation with the Default settings which are only a basic settings.

The system is now ready to be adjusted with the optimal air volumes and the operational desires and demands for the dwelling in question, e.g. weekly operation, temperatures etc. to achieve the most effective utilisation and operation of the system.

## 4. Operating

### Optima 301

All Genvex heat pumps of type Premium Preheat for dwellings are delivered with the Optima 301 control, which has a default setting so that the system can be put into operation without further setting.

The default setting is a basic setting that should be adapted to the operating desires and demands for the dwelling in question to achieve the most effective utilisation and operation of the system.

### 4.1 Operating and changing data in the operating menu

Normally, the symbols for daily operating options are displayed and the following pushbuttons can be seen:

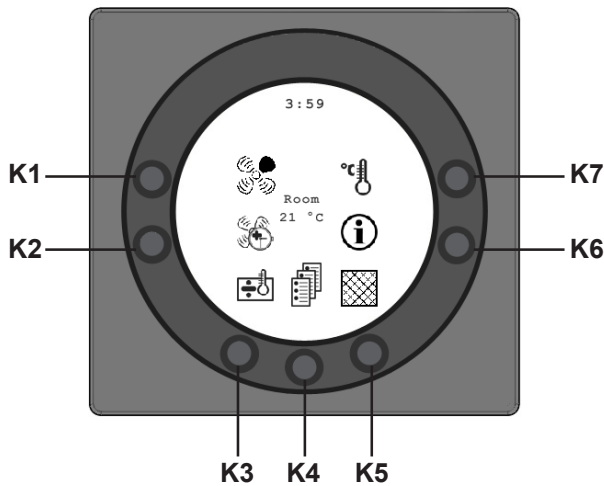

#### K1 - Speed

Use this function to set the fan speed to levels 0-1-2-3-4. Use the button next to the “Speed” symbol to change between the 4 speeds. The system can also be stopped by pressing the button for 3-4 seconds. It is a condition that service menu item 28 is ON.

#### K2 - Extended operation (Party mode)

Use this function to set the timer for fan speed level 4 to between 1 and 9 hours after which the unit automatically goes back to the fan speed level 3. If the timer is set to 0, this function is not in operation.

#### K3 - Reheater

Use this function to switch the electrical reheater on and off.

If a heating coil symbol without a cross is on the display, and the unit is equipped with a reheater, the reheater will switch on when there is a need.

If a heating coil symbol with a cross is on the display, and the unit is equipped with a reheater, the reheater will NOT switch on when there is a need .

#### K4 - Main menu

Use this function to enter the main menu and access the sub-menus Date and time, Calendar, User menu, Display menu, Info operation menu and Service menu.

#### K5 - Filter

Use this function to reset the filter alarm. To reset the filter alarm, press the button next to the “Filter” symbol until the exclamation mark in the symbol disappears. Before the filter alarm is reset, the filters should be controlled/changed.

#### K6 - Information

Use this function to to enter the Operation info menu and get an good overview of the current operating condition: Temperatures, fan settings, relay status ON/OFF, alarms and time cues.

Press the button next to the the symbol “Info” to read the operating status of the unit.

#### K7 - Temperature

Use this function to set the desired temperature. Press the key next to the “Temperature” symbol to set the desired temperature between 10 and 30 °C. The current temperature will be displayed at the centre of the screen.

When you press the button **K4** you will enter the main menu and sub-menus and the following buttons will change functions:

**K3** changes to “Arrow down ” and when changing the setting to “-”.

**K4** changes to “Enter”. Press “Enter” to proceed through the menus and sub-menus.

**K5** changes to “Arrow up” and when changing the setting to “+”.

**K6** changes to “Exit”. Press “Exit” to return to the previous screen.

**K7** changes to “Help”. Press “Help” to see a short description of the current menu item.

The horizontal arrow in the menu shows the current location. To save changes to a menu item, finish by pressing “Enter”.

## 4.2 Main menu

There is a "Book" symbol at the bottom centre of the screen with the daily operating options. Press this button **K4** to enter the main menu, which is divided into the following menu items:

 Date and time (item 4.3)

 Calendar (item 4.4)

 User menu (item 4.5)

 Display (item 4.6)

 Operation Info (item 4.7)

 Service menu (item 4.8)

By pressing "Arrow down" or "Arrow up" the symbol will change into a horizontal arrow that shows the current location.



Press "Enter" to access the sub-menus of the current menu. Press "Arrow down" or "Arrow up" again to select the required sub-menu. When the horizontal arrow is next to a sub-menu, the 2 lines will change place, the font sizes will change and the text "Set" will be added.

When pressing "Enter" next to the selected sub-menu the background of the menu item will change into grey. Use the "+" and "-" buttons to change the current value. Press "Enter" again to save the change.

If no changes are required, press "Exit" to return to the previous menus.

Press "Help" to get a brief help text on the screen that explains the menu item. Press one of the buttons to exit the help text.

After a short period of non-activity, the control will automatically exit the menus.

## 4.3 Date and time

Use this function to set and change the date and time. The function is divided into the following menu items:

### 01 Hours

Enter the current hour here. When changing between summer and winter time you have to manually set the time one hour forward or backward.

### 02 Minutes

Enter the current number of minutes here.

### 03 Weekday

Enter the current day of the week here.

### 04 Date

Enter the current date here.

### 05 Month

Enter the current month here.

### 06 Year

Enter the current year here.

#### Weekday

|           |   |
|-----------|---|
| Monday    | 1 |
| Tuesday   | 2 |
| Wednesday | 3 |
| Thursday  | 4 |
| Friday    | 5 |
| Saturday  | 6 |
| Sunday    | 7 |

#### Month

|           |    |
|-----------|----|
| January   | 1  |
| February  | 2  |
| March     | 3  |
| April     | 4  |
| May       | 5  |
| June      | 6  |
| July      | 7  |
| August    | 8  |
| September | 9  |
| October   | 10 |
| November  | 11 |
| December  | 12 |

## 4.4 Calendar

This function will set and change settings for the different days of the week. Every weekday can be set to run with different fan speeds as required. The settings can be copied from one weekday to the next. It is possible to set ON or OFF, i.e. if no one is in residence during a period of time the daily settings can be turned off and the unit will run a manual setting, e.g. level 1. The function is divided into the following menu items:

### 01 - Calendar

Choose between controlling the unit manually or controlling the speed (air change) and temperature automatically according to a set weekday program.

If the menu item is set to OFF, the unit is manually controlled according to the speed and temperature that has been chosen.

If the menu item is set to ON, the unit is controlled by those weekday programs that are programmed in menu items 02 to 08.

Setting option: ON/OFF.

Default setting: OFF.

### 02 - Monday

A maximum of 10 change time points can be set for one weekday. The time points can be set in any order. The hours are set in the first column, minutes in the second column, speed in the third column, and in the fourth column the desired reduction in temperature is set.

**Example: If the temperature is set to 21 °C and you set – 2.0 °C then the unit will be controlled at 19 °C.**

If the speed has been changed manually with the button during daily operation, then the program will revert to the weekday program when the next change in time point is passed.

**Examples of a day program:**

- 01** 07:30 H3 -0,0
- 02** 09:15 H1 -1,0
- 03** 17:00 H3 -0,0
- 04** 18:00 H2 -0,0
- 05** 23:30 H2 -2,0

It is not necessary to use all the change time points. If the whole line has a 0, it will be passed over by the control.

**03 - to 08**

These days can be added to individually in the same manner as under item 02.

**09 - Copy day**

This menu item can copy one weekday to another when the same change time points, speeds and temperature reductions are required. For example: From Thursday to Tuesday.

**4.5 User menu** 

This menu is divided into the following sub-menu items:

**01 - Temperature**

In service menu Item 19 you can choose between room or extract air temperature regulation (the room sensor is in the control panel).

Setting option: between 10 and 30 °C.

*Default setting: 21 °C.*

**02 - Cooling**

To prevent the cooling of the supply air starting as soon as no heat is required, configure how many degrees the temperature must be above the set temperature in user menu item 1 before the cooling may start.

Setting option: between 3 and 10 °C.

*Default setting: 3 °C.*

**03 - Cooling ON/OFF**

If the setpoint is set to ON, the unit will cool when the sensor registers a higher temperature than the temperature set in user menu item 2.

If the cooling function is not wanted, the set point is set to OFF.

Setting option: ON/OFF.

*Default setting: OFF.*

**04 - Timer 3-4**

At speeds 3 and 4, the unit will automatically return to speed 2 according to the number of hours set in service menu item 17, since the setpoint is set to ON.

If the setpoint is set to OFF, the unit will run at speed 3 or 4 until it is manually changed to another speed.

Setting option: ON/OFF.

*Default setting: OFF.*

**05 - Filter change**

There is a built-in filter timer that counts how long the unit has been in operation since the last filter change.

The setpoint can be set between 1 and 6 months. We recommend setting the setpoint at 3 the first time.

If the filters are dirty after the set period, the setpoint can be set to a fewer number of months.

If no change of filters is necessary after the set period, then the setpoint can be set to a greater number of months.

When the timer reaches the set value for filter change, the text "Alarm!" will flash on the upper part of the screensaver and the text "Change Filter" flashes just below.

When the filters have been changed the display for daily operations will return and the button for the filter symbol must be pressed down until the exclamation mark disappears and the unit returns to normal operation.

Setting option: between 1 and 6 months.

*Default setting: 3.*

**4.6 Display menu** 

This function can set and change the following sub-menus:

**01 - Language**

It is possible to choose between several different languages in the display.

**02 - Program info**

This menu shows the control version and the version number of the unit:

**Example: Optima 301 UK D: 3.0 C: 1.0**

D stands for the version number of the control panel.

C stands for the circuit board's version number in the unit.

**03 - Screensaver**

The following settings can be chosen here:

- 0:** Screensaver off (daily use options are shown)
- 1:** Screensaver off but with light dimming
- 2:** Temperature + light dimming
- 3:** Time + light dimming
- 4:** Time and temperature + light dimming
- 5:** Black screen + light dimming

Setting option: between 0 and 5.

*Default setting: 3.*

#### 04 - Pause time

Set the period of time to pass from no symbols on the display being used for daily operation until it automatically switches back to the screensaver. The variable from the daily menu to the screensaver is 1 to 10 minutes. The other automatic re-couplings cannot be changed. If a button is not pushed within the time set it will automatically revert to the previous display image:

- Change in menu item back to menu item = 30 s.
- From menu item to main menu = 2 min.
- From menu item to daily menu = 2 min.

Setting option: between 1 and 10 min.  
*Default setting: 10 min.*

#### 05 - Auto wake-up

It is possible to disconnect the function "Auto-awakening" that can be used to shift from the screensaver to the display image with symbols for the daily use options by passing the hand over the control panel.

Setting option: between 0 and 4.  
*Default setting: 1.*

|     |                 |
|-----|-----------------|
| "0" | OFF             |
| "1" | Most sensitive  |
| "2" | Level 2         |
| "3" | Level 3         |
| "4" | Least sensitive |

#### 06 - Auto light intensity

A motion detector is included in the display.

Setting option: ON/OFF.  
*Default setting: ON.*

#### 07 - Light day

Set the maximum light intensity desired when the room is fully lit.

Setting option: between 0 and 100 %.  
*Default setting: 100 %.*

#### 08 - Light night

Set the minimum light intensity desired when using the room in full darkness.

Setting option: between 0 and 100 %.  
*Default setting: 30 %.*

#### 09 - Light day pause

Set the maximum light intensity desired for the screensaver when the room is fully lit.

Setting option: between 0 and 100 %.  
*Default setting: 50 %.*

#### 10 - Light night pause

Set the minimum light intensity desired for the screensaver when the room is in full darkness.

Setting option: between 0 and 100 %.  
*Default setting: 0 %.*

#### 11 - Factory reset

If the setpoint is set so that the facility does not work as expected and it is not possible to find the cause, then you can choose between 2 different resets of the menu items for the default settings.

- **Press 1** to change all menu items of the default settings with the exception of the menu items for Speed (Level), Filter timer, Calendar and Defrost temperatures.
- **Press 2** to change all menu items of the default settings.

N.B. Make sure that currently set values are noted in "Schedule for setpoints" before resetting.

Setting option: between 0 and 2.  
*Default setting: 0.*

#### 12 - Security menu

It is possible to prevent access to certain display menu items so that they cannot be changed without a code consisting of 4 numbers.

Press 4 times on 0 the first time and then "Enter". Display menu items 13 to 18 will then open.

A new code can be chosen in display menu item 18 that is to be used.

#### 13 - Date and time

If this item is set to ON it will not be possible to enter the Date and Time menu without access to the code chosen in item 18.

Setting option: ON/OFF.  
*Default setting: OFF.*

#### 14 - Calendar

If this item is set to ON it will not be possible to enter the Calendar menu without access to the code chosen in item 18.

Setting option: ON/OFF.  
*Default setting: OFF.*

#### 15 - User menu

If this item is set to ON it will not be possible to enter the User menu without access to the code chosen in item 18.

Setting option: ON/OFF.  
*Default setting: OFF.*

#### 16 - Display

If this item is set to ON it will not be possible to enter the Display menu without access to the code chosen in item 18.

Setting option: ON/OFF.  
*Default setting: OFF.*

#### 17 - Service menu

If this item is set to ON it will not be possible to enter the Service menu without access to the code chosen in item 18.

Setting option: ON/OFF.  
*Default setting: OFF.*

## 18 - Password

Here you enter the password, which is to be used in the display menu item 12 to enter in display menu items 13 to 18.

Contact Genvex After Sales for help if you forget the code. If you want to change the code, enter a new code in this menu item and then press "Enter" to save the change.

## 4.7 Operation Info

In the "Operations Info Menu" it is possible to see an overview of the current operating conditions of the unit.

If you want to see the operating conditions of the unit over a period of time you can connect the control panel to a computer and use the Genlog data log program. The unit reads the operating conditions of the unit and saves the data for up to two years on the SD-card.

Operation info is divided into the following pages:

### Current temperature

The current temperatures can be viewed by pressing "Enter" on the "Operations Info Menu".

|    |                   |
|----|-------------------|
| T1 | Supply air        |
| T2 | Room              |
| T3 | Fresh air         |
| T4 | Exhaust air       |
| T5 | Before evaporator |
| T6 | Evaporator        |
| T7 | Extract air       |
| T8 | T8 Sensor         |
| T9 | T9 sensor         |

### Current fan speeds

Press "Arrow down" to show the current fan speed percentages, opening of the external bypass and water valve and the fan revolutions per minute.

|                 |      |
|-----------------|------|
| Supply air      | in % |
| Extract air     | in % |
| External bypass | in % |
| Water valve     | in % |
| Supply air      | in R |
| Extract air     | in R |

## Current setting of operation relays

Press "Arrow down" again to display the current status of the operation relays.

|    |                   |
|----|-------------------|
| R1 | Compressor        |
| R2 | Reheater          |
| R3 | Preheater         |
| R4 | Defrost           |
| R5 | Reheater 1 (R10)  |
| R6 | Preheater 2 (R11) |
| R7 | Not in use        |
| R8 | Cooling           |
| R9 | Aux. relais 9     |

## Current alarm overview

Press "Arrow down" once more to show the current alarm. It is activated when ON is displayed beside the alarm, which also shows on the screensaver and the display for daily use options where "Alarm" is visible at the top. The "Operations Info" menu shows which alarm applies. When the time reaches the set value for filter change, the alarm "Change filter" will flash at the top of the screensaver and the text "Change Filter" flashes just below. When the filter has been changed and the alarm has been reset then OFF will be displayed.

| Error message        | Status | Error for „ON“                                                                                                                                            |
|----------------------|--------|-----------------------------------------------------------------------------------------------------------------------------------------------------------|
| Stop control         | ON/OFF | Filter not changed within 14 days. It is possible to mount an external stop at L8, terminals 1 and 2. Once these are short-circuited, the unit will stop. |
| Change filter        | ON/OFF | The filters must be changed.                                                                                                                              |
| High pressure switch | ON/OFF | High pressure fault in the cooling system.                                                                                                                |
| *)                   | ON/OFF |                                                                                                                                                           |
| Com error            | ON/OFF | The control panel cannot communicate with the main circuit board (between display and circuit card).                                                      |
| *)                   | ON/OFF |                                                                                                                                                           |
| *)                   | ON/OFF |                                                                                                                                                           |
| SD-card err.         | ON/OFF | Faulty or missing SD card.                                                                                                                                |

\*) Not in use

## Time cue (2 pages)

Press "Arrow down" once more to show the time cue that counts from that day the unit was commissioned. The numbers shown must be multiplied by 10. It shows how many hours the unit has been in use and how many hours the unit has run the different speeds, as well as how many hours the relays have been connected (ON).

|                          |  |
|--------------------------|--|
| Total time               |  |
| Level 0                  |  |
| Level 1                  |  |
| Level 2                  |  |
| Level 3                  |  |
| Level 4                  |  |
| Relay 1 Compressor       |  |
| Relay 2 Reheater         |  |
| Relay 3 Preheater        |  |
| Relay 4 Defrost          |  |
| Relay 5 Reheater 1 (R10) |  |
| Relay 6 Reheater 2 (R11) |  |
| Relay 7 Not in use       |  |
| Relay 8 Cooling          |  |
| Relay 9 Aux. relay       |  |

Press Exit to return to the main menu.

## 4.8 Service menu

This function will set and change the following sub-menu items.

### 10 - Level 1 supply air

Level 1 is the lowest speed often used when no one is home.

Setting option: between 0 and 100 %.

*Default setting: 25 %.*

### 11 - Level 2 supply air

Level 2 is that speed the unit is recommended to run at in order to give optimal indoor climate and must be set to the ventilation necessary for the residence.

Setting option: between 0 and 100 %.

*Default setting: 40 %.*

### 12 - Levels 3 and 4 supply air

Level 3 is the highest speed that can be set. It is used e.g. when there are a lot of people or much activity in the kitchen.

Setting option at level 3: between 0 and 100 %.

*Default setting at level 3: 70 %.*

Level 4 is used especially during the summer when there is a wish to reduce the indoor temperature.

Setting option at level 4: none.

*Default setting at level 4: 100 %.*

### 13 - Level 1 extract air

The fan speed is regulated until the same air volume as the supply air in level 1 is reached.

Setting option: between 0 and 100 %.

*Default setting: 25 %.*

### 14 - Level 2 extract air

The fan speed is regulated until the same air volume as the supply air in level 2 is reached.

Setting option: between 0 and 100 %.

*Default setting: 40 %.*

### 15 - Levels 3 and 4 extract air

The fan speed level 3 is regulated until the same air volume as the supply air in level 3 is reached.

Setting option at level 3: between 0 and 100 %.

*Default setting at level 3: 70 %.*

Setting option at level 4: none.

*Default setting: 100 %.*

### 16 - T2 adjustment

The room sensor can be finely tuned so that the display shows the actual room temperature.

Setting option: between 0 and -5 °C.

*Default setting: -3 °C.*

### 17 - Timer 3-4

If automatic re-coupling for speed 3 or 4 is used you can set how many hours the unit will run at level 3 or 4 before it is automatically reconnected to level 2.

Setting option: between 1 and 9 hours.

*Default setting: 3 hours.*

### 18 - Filter/stop

The setpoint can be set to ON to guarantee filter change when the control panel flashes "Change filter". The unit will then automatically stop after 14 days if the filters have not been changed during that period.

If you don't want this reminder then the setpoint can be set to OFF so that the unit will continue to run.

Setting option: ON/OFF.

*Default setting: OFF.*

### 19 - Regulation method

Choose between two regulation possibilities:

- 0. Room regulation (T2 sensor)
- 1. Extract air regulation (T7 sensor)

Setting option: between 0 and 1.

*Default setting: 1.*

### 20 - Preheat ON/OFF

If you do not wish use the internal preheat function, you can set the function to OFF. The desired preheating temperature is set in service menu item 21.

Setting option: ON/OFF.

*Default setting: ON.*

### 21 - Preheat

Here the desired outdoor temperature is set at which the internal preheater is to switch on.

Setting option: between -15 and 0 °C.

*Default setting: -3 °C.*

## 22 - Regulation water

If a water reheater with a motor valve is installed it may be necessary to change the regulating time. The less the regulation time, the faster the motor valve will regulate.

Setting option: between 1 and 250 s.

*Default setting: 20 s.*

## 23 - Regulation of electrical reheater

It may be necessary to change the regulating time for electrical reheater.

Setting option: between 1 and 30 min.

*Default setting: 3 min.*

## 24 - Min. air volume

In order to achieve optimal performance of the system, the air flows should correspond to at least the air flows listed in the data sheet for the unit in question. If the supply air flow and the extract air flow are set lower than the minimum requirement, the heat pump will stop and only heat changed air will be blown into all the living rooms.

Setting option: between 0 and 100 %.

*Default setting: 30 %.*

## 25 - Frost protection

If the unit has a waterborne reheater with a motor valve then it must be equipped with a frost sensor and the setpoint set to ON.

If no frost sensor has been added then set the setpoint to OFF.

Setting option: ON/OFF.

*Default setting: OFF.*

## 26 - Frost protection temperature

If the frost protector in service menu item 25 is set to ON, then the desired frost temperature must be set to that temperature the unit will be shut off and the motor valve opened completely for the inflow of hot water.

Setting option: between 0 and 10 °C.

*Default setting: 5 °C.*

## 27 - Aux. relais R9, H17

This function can be used for the following:

| Setpoint. | Function                                                                                                         |
|-----------|------------------------------------------------------------------------------------------------------------------|
| 0         | Relay is turned off                                                                                              |
| 1         | Relay is on when the unit is in use. It may e.g. be used to open and close the fresh air and exhaust air damper. |
| 2         | The relay is on when there is need for extra heat.                                                               |
| 3         | The relay is on when the unit displays "Change filter". This can be used to activate an external alarm.          |
| 4         | The relay is on when extra cooling is necessary.                                                                 |

|   |                                                                                                                                                                                                                                                                                                                                                                                                                                                         |
|---|---------------------------------------------------------------------------------------------------------------------------------------------------------------------------------------------------------------------------------------------------------------------------------------------------------------------------------------------------------------------------------------------------------------------------------------------------------|
| 5 | The control can manage a ground heat changer with a damper. The relay will be on under one of the following two conditions: <ul style="list-style-type: none"><li>- The outdoor temperature, sensor T9, is lower than the set value in item 26 (frost temperature, typically set to 5°C).</li><li>- The outdoor temperature, sensor T9, is more than 1°C above the set temperature in user menu item 1 and 1°C above the current temperature.</li></ul> |
| 6 | This function is used to control an additional damper mounted on the connection on the rear side of the unit. In this way you can guide air around the heater in order to cool a room, eg. the bedroom. The relay is ON when the temperature is 1°C higher than the value set in the service menu item 40.                                                                                                                                              |

Setting option: between 0 and 6.

*Default setting: 0.*

## 28 - Stop unit

Set if the unit will be turned off by pressing button **K1** in the Operations menu for 3-4 s. If the value is OFF, the unit cannot be turned off.

Setting option: ON/OFF.

*Default setting: ON.*

## 29 - Stop defrost

As default the defrosting period ends when the evaporator has reached a temperature of 5°C. It may be necessary to change this temperature to a higher value under certain operating conditions where the evaporator is not completely defrosted.

Setting option: between 0 and 15 °C.

*Default setting: 5 °C.*

*Please note: Should only be changed under expert advice.*

## 30 - Compressor dif.

The default temperature difference between start/stop compressor is ± 0.4°C. It is recommended to change the temperature difference under certain operating conditions.

Setting option: between 0.1 and 1.0 °C

*Default setting: 0.4 °C.*

*Please note: Should only be changed under expert advice.*

## 31 - Constant ON/OFF

If the other heating system of the residence is not connected to the heat pump system, the other heating system, e.g. burning oven, can stop the heat pump so that the heat pump system only blows heat recovered air into all living rooms. This can cause increasing draft problems, the colder it gets outside.

Setting the set point to ON will disconnect the room sensor. The heat pump will always operate and blow in warm air when the fresh air temperature is below the temperature set in service menu item 32.

If the set point is set to OFF, the room sensor will regulate the heat pump regardless of the fresh air temperature.

Setting option: ON/OFF.

*Default setting: ON.*

### 32 - Constant

If the service menu item 31 is set to ON, you are to set the minimum air temperature on the fresh air side of the heat changer, before the heat pump function must disconnect. Setting option: between 0 and 10 °C.  
*Default setting: 4 °C.*

### 33 - Reduction

At very low fresh air temperatures, lowering the supply air flow is recommended in order to improve the operating conditions of the heat pump and also to achieve a higher supply air temperature, although the same air flow is still being extracted.

By setting the setpoint to ON, the supply air flow will be lowered when the fresh air temperature is below the set temperature.

If the set point is set to OFF, the supply air flow will not be reduced. This setting applies when a preheater is installed. If a burning oven is installed in the residence, this setting should be used with care.

Setting option: ON/OFF.

*Default setting: OFF.*

### 34 - Reduce supply air volume

When the setpoint is set to ON in service menu item 33, you can set the fresh air temperature at which the function has to be in operation in this menu point.

We recommend that the fresh air temperature is set to -10 °C.

The set point can be configured between -15 and 0 °C.

Setting option: between -15 and 0 °C.

*Default setting: -10 °C.*

### 35 - Supply air volume

When the set point is set to ON in service menu item 33, it is recommended to set the reduced supply air flow to 20 % below the setpoint set in service menu item 11.

Setting option: between 0 and 100 %.

*Default setting: 20 %.*

### 36 - Min. outdoor cooling

In order to prevent the system from cooling during winter, regardless of the room temperature, the fresh air temperature can be set to the temperature desired, before the cooling function is in operation. It is recommended that the temperature is set to at least 15 °C.

Setting option: between 0 and 20 °C.

*Default setting: 15 °C.*

### 37 - Reheat ON/OFF

If a reheater is installed, you can decide when you want the reheater to operate. Shortcut to this option is K3 on the daily operation screen.

If the setpoint is set to OFF, the reheater will not operate, even if there is a need for heat.

If the set point is set to ON, the reheater will operate when there is a need. It configures itself according to the temperature set in user menu item 1 minus 1 °C.

Setting option: ON/OFF.

*Default setting: OFF.*

### 38 - Additional electrical preheating ON/OFF

If an electrical preheater with multiple heating levels is fitted over an additional relay, the setpoint must be set to ON.

If there is no additional relay, the set point must be set to OFF.

Setting option: ON/OFF.

*Default setting: OFF.*

### 39 - Additional electrical preheating

If the additional electrical preheating is set to ON in service menu item 38, the set point must be set to the desired fresh air temperature to which, the electrical preheater should heat the fresh air before the heat changer.

Setting option: between -25 and 0 °C.

*Default setting: -10 °C.*

### 40 - Bedroom

If a lower temperature is desired in the bedroom or in any other room than the value set in user menu item 1, there is an option to fit an extra damper between the supply air duct and the duct connection for the bedroom and control the temperature in the room in question with a room sensor (T9) by setting the set point to 6 in service menu item 27.

Setting option: between 10 and 25 °C.

*Default setting: 20 °C.*

### 44 – Fan Diff.

Here you enter the max. acceptable difference between supply air and extract air volume. When the set point is set to 0, the function is not in operation.

Setting option: between 0 and 100 %.

*Default setting: 0 %.*

### 45 \*) – Modbus mode

Setting options:

0 = OFF

1 = 9600 baud

2 = 19,200 baud

*Default setting: 0.*

### 46 \*) – Modbus address

Setting options: 1-247 addresses

*Default setting: 1.*

### 47 – Defrost supply air

Here you enter the max. acceptable difference between supply air and extract air volume. When the set point is set to 0, the function is not in operation.

Setting option: between 0 and 40%.

*Default setting: 0 %.*

#### 48 – Service mode

Only to be used by service technicians. This function is used in connection with the adjustment of the individual fan speeds. If you do not use this function, there is a danger that the control can change fan speed during balancing of the ventilation system. Remember to change the mode back to 0 to disable the feature. Should you forget it, the function will be automatically disabled after 6 hours.

Setting options:

- 0 = OFF
- 1 = Fan level 1
- 2 = Fan level 2
- 3 = Fan level 3
- 4 = Fan level 4

*Default setting: 0.*

*\*) 45+46: Only displays with Modbus.*

#### 4.9 Schedule for defrosting

| Before evaporator °C | Evaporator °C |
|----------------------|---------------|
| 15                   | -2            |
| 14                   | -2            |
| 13                   | -2            |
| 12                   | -2            |
| 11                   | -2            |
| 10                   | -2            |
| 9                    | -2            |
| 8                    | -2            |
| 7                    | -2            |
| 6                    | -2            |
| 5                    | -2            |
| 4                    | -2            |
| 3                    | -3            |
| 2                    | -4            |
| 1                    | -4            |
| 0                    | -5            |
| -1                   | -6            |
| -2                   | -6            |
| -3                   | -7            |
| -4                   | -7            |

## 4.10 Schedule for weekly programs

| Monday |       |         |       |         |
|--------|-------|---------|-------|---------|
|        | Hours | Minutes | Speed | Red. T2 |
| 1)     |       |         |       |         |
| 2)     |       |         |       |         |
| 3)     |       |         |       |         |
| 4)     |       |         |       |         |
| 5)     |       |         |       |         |
| 6)     |       |         |       |         |
| 7)     |       |         |       |         |
| 8)     |       |         |       |         |
| 9)     |       |         |       |         |
| 10)    |       |         |       |         |

| Tuesday |       |         |       |         |
|---------|-------|---------|-------|---------|
|         | Hours | Minutes | Speed | Red. T2 |
| 1)      |       |         |       |         |
| 2)      |       |         |       |         |
| 3)      |       |         |       |         |
| 4)      |       |         |       |         |
| 5)      |       |         |       |         |
| 6)      |       |         |       |         |
| 7)      |       |         |       |         |
| 8)      |       |         |       |         |
| 9)      |       |         |       |         |
| 10)     |       |         |       |         |

| Wednesday |       |         |       |         |
|-----------|-------|---------|-------|---------|
|           | Hours | Minutes | Speed | Red. T2 |
| 1)        |       |         |       |         |
| 2)        |       |         |       |         |
| 3)        |       |         |       |         |
| 4)        |       |         |       |         |
| 5)        |       |         |       |         |
| 6)        |       |         |       |         |
| 7)        |       |         |       |         |
| 8)        |       |         |       |         |
| 9)        |       |         |       |         |
| 10)       |       |         |       |         |

| Thursday |       |         |       |         |
|----------|-------|---------|-------|---------|
|          | Hours | Minutes | Speed | Red. T2 |
| 1)       |       |         |       |         |
| 2)       |       |         |       |         |
| 3)       |       |         |       |         |
| 4)       |       |         |       |         |
| 5)       |       |         |       |         |
| 6)       |       |         |       |         |
| 7)       |       |         |       |         |
| 8)       |       |         |       |         |
| 9)       |       |         |       |         |
| 10)      |       |         |       |         |

| Friday |       |         |       |         |
|--------|-------|---------|-------|---------|
|        | Hours | Minutes | Speed | Red. T2 |
| 1)     |       |         |       |         |
| 2)     |       |         |       |         |
| 3)     |       |         |       |         |
| 4)     |       |         |       |         |
| 5)     |       |         |       |         |
| 6)     |       |         |       |         |
| 7)     |       |         |       |         |
| 8)     |       |         |       |         |
| 9)     |       |         |       |         |
| 10)    |       |         |       |         |

| Saturday |       |         |       |         |
|----------|-------|---------|-------|---------|
|          | Hours | Minutes | Speed | Red. T2 |
| 1)       |       |         |       |         |
| 2)       |       |         |       |         |
| 3)       |       |         |       |         |
| 4)       |       |         |       |         |
| 5)       |       |         |       |         |
| 6)       |       |         |       |         |
| 7)       |       |         |       |         |
| 8)       |       |         |       |         |
| 9)       |       |         |       |         |
| 10)      |       |         |       |         |

| Sunday |       |         |       |         |
|--------|-------|---------|-------|---------|
|        | Hours | Minutes | Speed | Red. T2 |
| 1)     |       |         |       |         |
| 2)     |       |         |       |         |
| 3)     |       |         |       |         |
| 4)     |       |         |       |         |
| 5)     |       |         |       |         |
| 6)     |       |         |       |         |
| 7)     |       |         |       |         |
| 8)     |       |         |       |         |
| 9)     |       |         |       |         |
| 10)    |       |         |       |         |

**Red. T2 = Reduced room temperature  
(night reduction)**

## 4.11 Schedule for setpoints

| Item:    | Head line:                              | Default setting: | Setting option: | Date: | Date: | Date: | Date: |
|----------|-----------------------------------------|------------------|-----------------|-------|-------|-------|-------|
| (4.5) 1  | Temperature                             | 21 °C            | 10 - 30 °C      |       |       |       |       |
| 2        | Cooling                                 | 3 °C             | 3 - 10 °C       |       |       |       |       |
| 3        | Cooling ON/OFF                          | OFF              | ON / OFF        |       |       |       |       |
| 4        | Timer 3 - 4                             | OFF              | ON / OFF        |       |       |       |       |
| 5        | Filter change                           | 3 months         | 1 - 6 months    |       |       |       |       |
| (4.8) 10 | Level 1 supply air                      | 25 %             | 0 - 100 %       |       |       |       |       |
| 11       | Level 2 supply air                      | 40 %             | 0 - 100 %       |       |       |       |       |
| 12       | Level 3 and 4 supply air                | 70 / 100 %       | 0 - 100 %       |       |       |       |       |
| 13       | Level 1 extract air                     | 25 %             | 0 - 100 %       |       |       |       |       |
| 14       | Level 2 extract air                     | 40 %             | 0 - 100 %       |       |       |       |       |
| 15       | Level 3 and 4 extract air               | 70 / 100 %       | 0 - 100 %       |       |       |       |       |
| 16       | T2 Adjustment                           | ± 3 °C           | ± 5 - 0 °C      |       |       |       |       |
| 17       | Timer 3 - 4                             | 3 hours          | 1 - 9 hours     |       |       |       |       |
| 18       | Filter/stop                             | OFF              | ON / OFF        |       |       |       |       |
| 19       | Regulation method                       | 1                | 0 - 1           |       |       |       |       |
| 20       | Preheat ON/OFF                          | ON               | ON / OFF        |       |       |       |       |
| 21       | Preheat                                 | ± 3 °C           | ± 15 - 0 °C     |       |       |       |       |
| 22       | Regulation water                        | 20 s             | 1 - 250 s       |       |       |       |       |
| 23       | Regulation of electrical reheater       | 3 min.           | 1 - 30 min.     |       |       |       |       |
| 24       | Min. air volume                         | 30 %             | 0 - 100 %       |       |       |       |       |
| 25       | Frost protection                        | OFF              | ON / OFF        |       |       |       |       |
| 26       | Frost protection temperature            | 5 °C             | 0 - 15 °C       |       |       |       |       |
| 27       | Help function R9, H17                   | 0                | 0 - 5           |       |       |       |       |
| 28       | Unit stop                               | ON               | ON / OFF        |       |       |       |       |
| 29       | Stop defrost                            | 5 °C             | 0 - 15 °C       |       |       |       |       |
| 30       | Compressor dif.                         | 0,4 °C           | 0,1 - 1,0 °C    |       |       |       |       |
| 31       | Constant ON/OFF                         | ON               | ON / OFF        |       |       |       |       |
| 32       | Constant                                | 4 °C             | 0 - 10 °C       |       |       |       |       |
| 33       | Reduction                               | OFF              | ON / OFF        |       |       |       |       |
| 34       | Reduce supply air volume                | ± 10 °C          | ± 15 - 0 °C     |       |       |       |       |
| 35       | Supply air volume                       | 20 %             | 0 - 100 %       |       |       |       |       |
| 36       | Min. outdoor cooling                    | 15 °C            | 0 - 20 °C       |       |       |       |       |
| 37       | Reheat                                  | OFF              | ON / OFF        |       |       |       |       |
| 38       | Additional electrical preheating ON/OFF | OFF              | ON / OFF        |       |       |       |       |
| 39       | Additional electrical preheating        | ± 10 °C          | ± 25 - 0 °C     |       |       |       |       |
| 40       | Bedroom                                 | 20 °C            | 10 - 25 °C      |       |       |       |       |
| 44       | Fan diff.                               | 0 %              | 0 - 100 %       |       |       |       |       |
| 45 *)    | Modbus mode                             | 0                | 0 - 2           |       |       |       |       |
| 46 *)    | Modbus adress                           | 1                | 1 - 247         |       |       |       |       |
| 47       | Defrost supply air                      | 20 %             | 0 - 100 %       |       |       |       |       |
| 48       | Service mode                            | 0                | 1 - 4           |       |       |       |       |

\*) 45+46: Only displays with Modbus.

## 5. Function

### 5.1 Regulation

#### Controlling the temperature

The temperature is controlled by either the T2 sensor in the display (room regulation) or the T7 sensor (extract air regulation).

If a temperature of e.g. 21 °C has been set, the compressor will start when the temperature falls to 20.6 °C. When the temperature reaches 21.4 °C, the compressor stops. If an electrical reheater has been installed and the compressor cannot maintain the temperature set, the electrical reheater will switch on when the temperature has fallen to 20 °C.

If the regulation time is set to e.g. 3 minutes, the sensor will measure whether the temperature is now above or below 20 °C after 3 minutes. If the temperature is still below 20 °C the reheater will continue heating.

When the temperature reaches 20 °C, the electrical reheater will switch off.

When the cooling starts, the supply air and extract air fans connect to speed level 3 and the 4-way-solenoid valve MA 7 opens so that the condenser on the supply air side becomes an evaporator and the evaporator on the extract air side becomes a condenser.

When the temperature has fallen 1 °C below the set temperature, the compressor stops and the fans return to normal operation. The 4-way-solenoid valve MA7 closes, until the bypass function is closed so that the evaporator on the supply air side becomes a condenser and the condenser on the extract air side becomes an evaporator.

If an extra cooling device has been installed in the system, this will engage when the temperature is 2 °C higher than start cooling.

The preheat function works as follows: If the the service menu item 20 is set to ON, and when the fresh air temperature is below the setpoint in the service menu item 21, the solenoid valve MA8 opens so that the refrigerant is passed through the built-in preheater, thus adding heat to the intake air. As soon as the fresh air temperature is 1 °C above the setpoint in the service menu 21, the solenoid valve MA8 closes again and no heat is added to the intake air.

#### Defrost

The system begins to defrost when the difference between the temperature before the evaporator and the temperature of the evaporator becomes too big. This occurs when ice forms on the evaporator. The solenoid valve MA4 opens and the supply air fan and the electrical heating coils stop until the ice has melted and the evaporator has reached a temperature of about 5 °C. Then the solenoid valve closes again and the supply air fan and the electrical heating coils start again.

### 5.2 Reliability

#### High pressure switch

In order to protect the compressor from exceeding its range of application, an electronic high pressure switch is built in that will disconnect when the pressure becomes too high. Once the cause of the error is found and corrected, then reset the pressure switch by switching off the unit for appr. 1 minute and then start up again.

#### Overriding the supply air fan

If the supply air temperature exceeds 45 °C and the speed of the supply air fan has not been set on 100 % at level 3, the speed of the supply air fan will begin to increase. The supply air temperature will be maintained at 45 °C, if possible.

#### Overriding the extract air fan

If the extract air temperature exceeds 45 °C and the speed of the extract air fan has not been set on 100 % at level 3, the speed of the extract air fan will begin to increase. The extract air temperature will be maintained at 45 °C, if possible.

## 6. Maintenance

For maintenance of the unit, refer to the installation instructions.

### Environmental requirements

When repairing or dismantling the unit, statutory environmental regulations must be observed regarding recycling and destruction of various materials.

### 6.1 Alarms

#### Filter timer

The control has a filter timer to guarantee that the filter is changed and that optimal operation is established. When the timer reaches the set value, "Chg. filter" will flash in the display until the filters have been changed.

When the filters have been changed, the button for the filter symbol must be held down until "Alarm!", "Chg. Filter" and the exclamation mark disappears and the unit reverts to normal operation.

#### Com error

This error appears when there is no communication between the display and control. Check that the wiring is correct on terminals 21 to 24.

|    |         |
|----|---------|
| 21 | Signal  |
| 22 | Signal  |
| 23 | 10 Volt |
| 24 | 0 Volt  |

#### Pressure switch error

When the high pressure switch disengages, then "ON" will appear next to "Pressostat" in the operation info menu. Once the cause of the error is found and corrected, then reset the pressure switch by switching off the unit for approx. 1 minute and then start up again.

#### SD-card err

Defect or packing SD-kort. Will not be registered as errors until after 6 hours 6 times in a row corresponding to 36 hours.

### 6.2 Disassembly/discontinue using the unit

#### Do as follows:

Switch off the electricity, i.e. disconnect all electric cables. Remove the condensation drains and electric cables to all re-/pre-heaters.

Remove leads to the control panel.

If the unit is being shut down, remove the ducts to prevent condensation from forming in the unit and ducts. Close all supply air and extract air valves.

## 7. Troubleshooting

### 7.1 High pressure switch

The electronic high pressure switch protects the heat pump from excessive pressure in the refrigerant circuit. In the event of disturbances, the high pressure switch will stop the compressor.

The cause of the failure is found and the pressure switch is reset by turning off system for approx. 1 minute and then start up again.

### 7.2 The unit is not running

#### Unit stopped

*Error:*

- Fuse in main board has blown, no power to unit.
- One of the fuses on the circuit board of the unit is blown.
- Loose wire, no power to unit.
- Loose wire between unit and control panel.
- Faulty or incorrectly set week program.
- High pressure switch is disengaged.
- Filter timer has switched the system off.

### 7.3 Air faults

#### No supply air:

*Error:*

- Faulty supply air fan
- Clogged supply air filter
- Clogged fresh air grill due to dirt and leaves during the fall and snow and ice during the winter.
- Fuse on the circuit board is blown.
- The unit is in defrost mode (supply air fan stops)
- Incorrect value set in service menu item 20.

#### No extract air:

*Error:*

- Faulty extract air fan
- Clogged extract air filter.
- Fuse on the circuit board is blown

#### Cold supply air:

*Error:*

- Clogged heat changer.
- Faulty extract air fan.
- Clogged extract air filter.
- Electrical reheater is disconnected at the over heating thermostat (only units with electrical reheater installed).
- Air in the heating pipes, faulty thermostat / motor valve, incorrect setting of control panel.

If none of the above mentioned errors apply please contact:

- *Within the guarantee period (0-2 years):*  
The installer from whom you have bought the unit.
- *After the guarantee period (2 years ->):*  
The installer from whom you have bought the unit or the Genvex Service Department (+45 7353 2765).  
Before calling, please have data from the name plate ready (silver plate on the unit).

# THE AIR WE BREATHE

All  
Genvex  
systems are  
rated with  
energy label

A

As of 1 January 2025, Genvex has merged with our parent company METRO THERM into one company under the name METRO THERM A/S.

With the merger, both physical addresses will be retained: The head office and production for METRO THERM will remain in Helsingø, while administration and production for Genvex and KVM-Conheat will remain at the Haderslev address as a subdivision.

The three strong brands - METRO THERM, Genvex and KVM-Conheat - remain unchanged and will continue to be treated as independent brands under METRO THERM A/S.



## Genvex - the original Danish ventilation system

Genvex is a true Danish original. We started producing ventilation systems in 1978 and are still the front runners when it comes to development and production of the most innovative and durable ventilation systems on the market.

Our units are installed in thousands of homes, providing clean, fresh air free from pollen, dust and harmful particles. They help lots of families with maintaining a healthy and comfortable indoor climate and prolong the longevity of the house itself. With very high heat recovery rates, a Genvex system lets you recover and reuse up to 95 % of the heat inside your home. As a result, our units provide a strong contribution to energy savings in both in family homes and in society as a whole.



Please visit [www.genvex.com](http://www.genvex.com) to see a list of our distributors