

INSTALLATION MANUAL

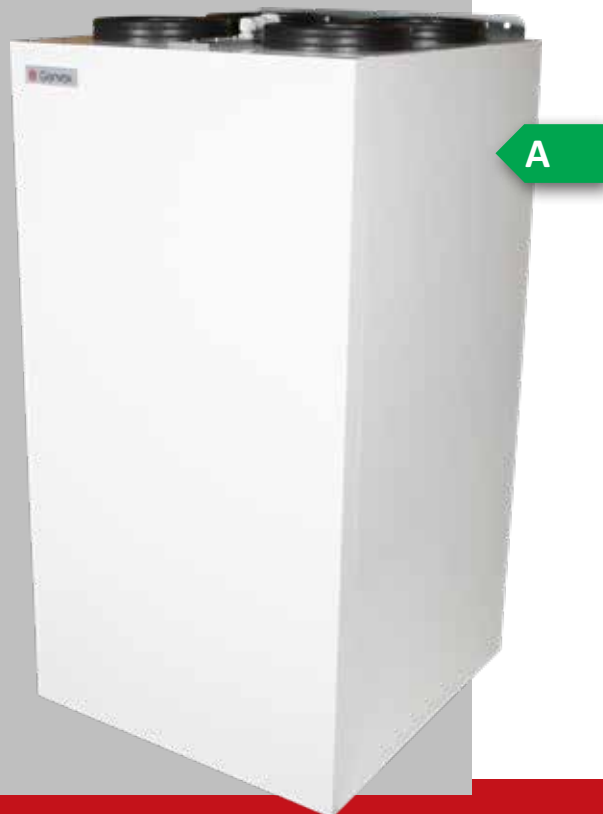

ECO 275

Mechanical ventilation with passive heat recovery

TABLE OF CONTENTS

Safety information	3
Functional description	4
Installation	5
Wall mounting (vertical connections)	6
Dimensional sketch	7
Duct connection (top).....	8
Duct connection (top/bottom - only for ECO 275 light).....	8
Condensate drain	10
Duct system	11
Insulation of ducts in cold attics	12
Insulation of ducts in heated rooms.....	12
Electrical installation	13
Control and calibration of the system.....	13
Optimal initial calibration of the system.....	13
System maintenance	14
Filters.....	14
Access to internal parts.....	15
Preheating surface.....	16
Fan	16
Supply air and exhaust air valves	16
Recommended maintenance intervals	17
Spare parts	18
Troubleshooting	19
Safety thermostat in electric heating surface	19
System not running.....	19
No supply air.....	19
No exhaust air	19
Cold supply air	19
Alerts	19
Circuit diagram, Optima 270 - right	20
Circuit diagram, Optima 270 - left	21
Declaration of Conformity	22
Deinstallation instructions	23

SAFETY INFORMATION

This manual also describes installation and service work to be performed by a professional.

This appliance can be operated by children aged 8 and over, by persons with reduced physical, sensory and mental abilities, and by persons with a lack of experience and knowledge, provided they are supervised or have received guidance on using the appliance in a safe way and understand the dangers involved. Children must not play with the appliance. Cleaning and user maintenance must not be performed by children without supervision.

Subject to design changes.

Labelling

The CE mark represents Genvex's assurance that the product complies with all regulations for the product in accordance with relevant EU directives. The CE mark is mandatory for most products sold in the EU, irrespective of where they are made.

FUNCTIONAL DESCRIPTION

ECO 275 is a wall-mounted ventilation system for comfort ventilation.

The system is equipped with a high-efficiency counter flow heat exchanger, which recovers the heat from the extract air from the home and preheats the fresh supply air.

ECO 275 can be configured as a right or left version depending on the installation conditions.

An integrated modulating preheater can be selected for the system, which ensures that balanced air volumes can be maintained – even during periods of very cold outdoor temperatures.

An integrated water level switch can also be purchased as an accessory, which ensures that the system is stopped and an alarm is shown in the display in the event of problems with the condensate drain (e.g. clogged floor drain).

ECO 275 is designed for an indoor setup but may – if the specific country requirements allow – it can also be used outside the building envelope in areas protected against weather conditions.

INSTALLATION

Please ensure sufficient earthing of the installation

IMPORTANT!

Follow these instructions when installing ECO 275:

1. Turn off the electricity before opening the unit.
2. Install an airtight water trap in a place without frost-free to compensate for the fan pressure.
3. The water trap must have a height of at least 50 mm.
4. Ensure that the condensate drain has a sufficient slope (at least -1%) towards the sewer.
5. Pour 1 litre of water into the condensate tray of the unit to check that it drains correctly. Make sure the condensate drain is filled with water before each heating season.
6. If the condensate drain is exposed to frost, a thermostat and an electric tracing device must be installed to prevent the drain from freezing when the temperature drops below +2°C.
7. Before commencing operation, adjustments must be made on both the supply and exhaust air. It is important to ensure a balance between the amounts of intake and exhaust air.
8. We recommend that you keep the ventilation ducts closed until the unit is started and the system is calibrated.

These instructions must be followed. If the installation is not carried out in accordance with these instructions, KVM-Genvex cannot be held liable for any potential further damage that extends beyond the Genvex unit.

KVM-Genvex A/S always recommends careful planning of the installation space for your Genvex product in relation to the location of living spaces. As this is a technical product that contains fans and/or a heat pump, in rare cases, and in combination with inappropriate installation conditions, it may cause unsatisfactory noise or vibration nuisance. As a general rule, it is always recommended to install the technical system so that it is not located in the immediate vicinity of a bedroom. Furthermore, when securing the Genvex unit to the building structure, it is recommended attaching it to a heavy structural component such as concrete. It should also be ensured that no sound or vibrations can be transmitted through materials in contact with the technical system. If there is a risk of propagation of noise and vibrations, further installation of vibration-dampening material and sound-dampening of installation rooms are recommended.

Wall mounting

Before starting the installation of the ventilation unit

Make sure that the wall used to hold the ventilation unit is built in such a way that it is able to support the weight of the unit. In addition, the wall must be straight and plumb.

ECO 275 comes with a pre-installed wall bracket as shown in Figure 1

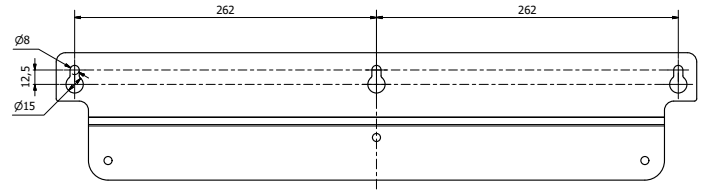

Figure 1

Before mounting the ECO 275, install a total of 3 Ø6-8 mm. bolts into the wall. The bolts should be installed level according to the dimensions as shown in Figure 1.

After installing the bolts, hang ECO 275 onto the bolts using the keyholes in the wall bracket.

The unit must be mounted level to ensure drainage from the condensate tray. If necessary, use the adjusting screw on the back of the unit to adjust the position of the unit.

Technical Drawing - left version (in mm)

In order to allow access for servicing and maintenance, there must be a clearance of at least 600 mm in front of the unit and 300 mm below the unit (to access the condensate drain and the water trap)

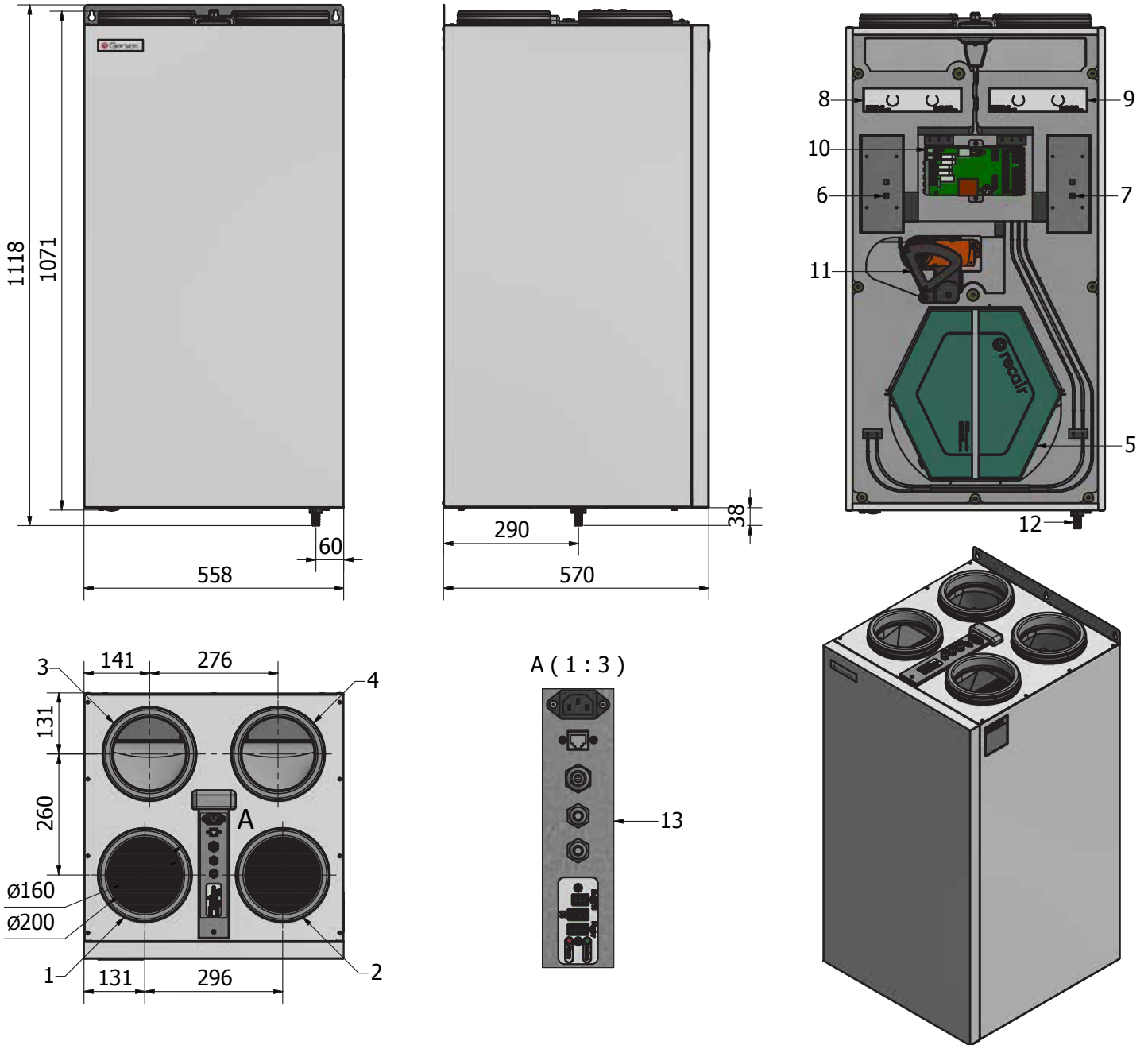

- | | |
|-------------------|------------------------------------|
| 1. Extract air | 8. Extract air filter |
| 2. Outdoor air | 9. Outdoor air filter |
| 3. Supply air | 10. PCB |
| 4. Exhaust air | 11. Bypass |
| 5. Heat exchanger | 12. Condensate drain |
| 6. Extract fan | 13. External electrical connection |
| 7. Supply air fan | |

Technical Drawing - Rigt version (in mm)

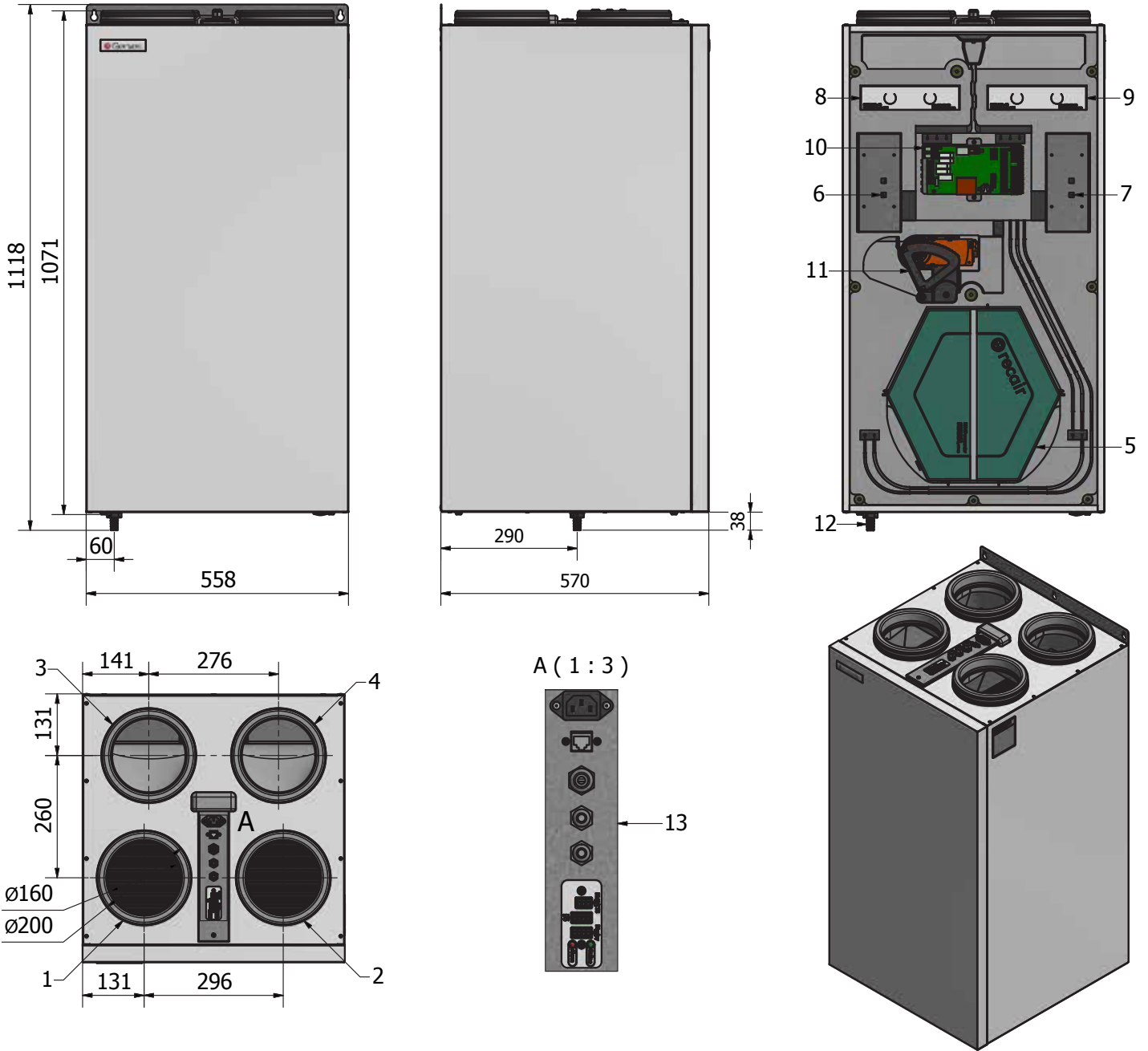

- | | |
|-------------------|------------------------------------|
| 1. Outdoor air | 8. Outdoor air filter |
| 2. Extract air | 9. Extract air filter |
| 3. Exhaust air | 10. PCB |
| 4. Supply air | 11. Bypass |
| 5. Heat exchanger | 12. Condensate drain |
| 6. Supply air fan | 13. External electrical connection |
| 7. Extract fan | |

Duct connection (top)

A yellow sticker glued to the front door indicates which ventilation ducts must be connected to the various sockets, depending on whether the system is configured right facing or left facing.

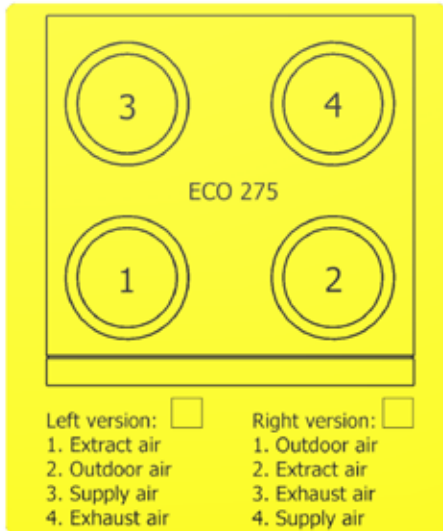

It is possible to reconfigure a unit from right facing to left facing and vice versa by relocating the humidity sensor, the clips for the exhaust air sensor in the exchanger, the sealing plug and the hose coupling nipple at the condensate drain (as well as any preheating surface and water level switch).

For more details on conversion, contact your Genvex sales representative.

Duct connection (top/bottom - only for ECO 275 light)

ECO 275 light can be delivered with a supply air connection at the bottom of the unit and can be configured both right facing or left facing. When using the bottom connection, the supply air connection at the top of the unit must be sealed off and the supply air connection at the bottom must be mounted with a $\varnothing 160$ mm nipple/nipple connection. The 3 other duct connections at the top must be connected as indicated above "duct connection top". If a bottom connection is desired for the ECO 275, this must be stated on the order placement to Genvex.

Right



Left



To begin the duct installation, it is recommended to use 4 x $\text{\O}160$ mm nipple connectors with double sealing lips.

Alternatively, a $\text{\O}200$ mm spiro pipe can be used that must be connected directly to the outside of the ECO 275 connection socket.





Condensate drain

The ventilation unit produces up to 6 litres of condensate per day. It is therefore important to mount the condensate drain correctly. An ordinary Ø15 mm hose can be connected directly to the ventilation unit.

It is important to make a loop in the hose to form a drain trap with a minimum of 50 mm. Water column.

There must be a slope of 1% from the drain trap and the hose towards the drain itself. If the unit is installed in a cold environment, the condensate drain must be insulated to prevent the condensate from freezing inside the pipe. However, it is recommended that the drain trap is installed in a heated area to ensure that the water inside does not freeze.

If installation problems make it impossible to secure the condensate drain against frost by means of insulation, it is necessary to install a thermostatically controlled heating wire around the condensate drain. During operation, the unit experiences internal negative pressure. Therefore, it is necessary to ensure a water column height of at least 50 mm in the drain trap under all conditions.

Left installation



Right installation



As ECO 275 may be used as a system configured for both right and left facings installation – the machine is delivered with a pre-installed plug inside the condensate drain that will not be used.

Carefully tighten the included hose coupling nipple until the O-ring seals against the head up into the thread connection where no plug is fitted. Then the condensate drain hose can be connected to the hose coupling nipple.

Check that the installation of the hose coupling nipple is correct by pouring water into the condensate tray and putting a finger on the outlet from the hose coupling nipple.

When having completed the installation – ensure that there are no leakages.



Duct system

It is recommended that the duct system should be made of spiral-folded pipes assembled with fittings with rubber ring seals so that you get a tight and durable duct system. In order to achieve a satisfactory noise level from the unit, sound locks must be installed on the supply air and exhaust air duct system between the unit and the first supply air and exhaust air vents.

To eliminate noise from the supply and exhaust air vents, it is recommended that the air velocities in the ducts are reduced to a sufficiently low level.

When positioning outdoor air and exhaust air hoods/gratings, it must be ensured that the two air flows do not short-circuit, thereby preventing the exhaust air from being sucked in again. It is recommended that bar screens are installed on the northern or eastern side of the house to achieve optimal comfort in houses/apartments. It is recommended that the air intake should be located on the north or east side of the house to achieve maximum comfort and minimal impact from the sun's heat.

The recommended minimum horizontal distance between air intake and exhaust air: 3 metres.

The recommended minimum vertical distance between air intake and exhaust air: 1 metre.

To connect ordinary galvanised steel ducts to the ECO 275 ventilation unit, you must first install 4 nipple connectors in the unit's $\text{\O}160$ mm openings (double sealing lips). Alternatively, $\text{\O}200$ mm galvanised steel ducts should be placed over the EPP connectors.

The unit is now ready for direct connection of ductwork to the nipple connector. It is recommended to install galvanised angle brackets to fasten the nipple connector to the galvanised housing using self-tapping steel screws.

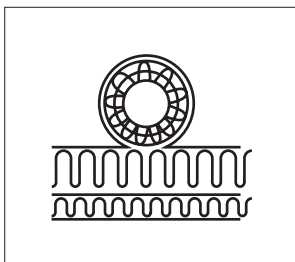
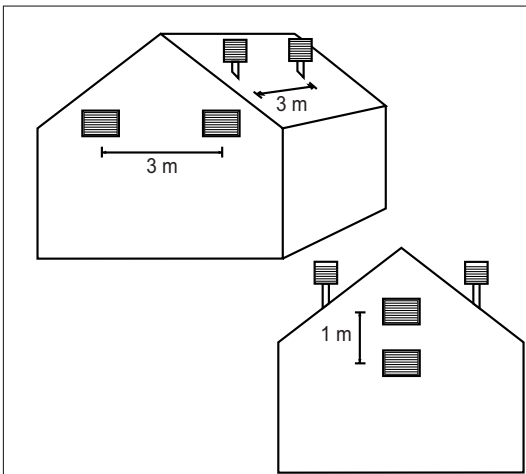

Ductwork insulation alt A

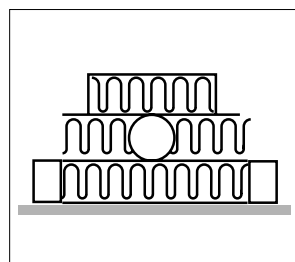

Ductwork insulation alt B

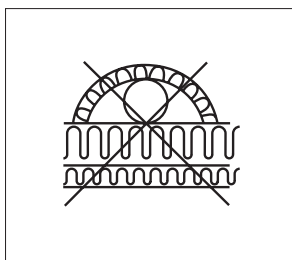

Wrong insulation

Insulation of ducts in cold attics

To benefit from the unit's high recovery potential (efficiency), the ducts must be correctly insulated.

Supply air and exhaust air ducts

In order to minimise heat loss from the duct system in cold attics, supply air and exhaust air ducts must be provided with at least 100 mm of insulation. If insulation from alternative A is used, it is recommended executing with two layers of 50 mm lamella mats with paper or foil externally and with staggered joints between the two layers. If the ducts are laid on the main beams of truss frames, alternative B can be used. The insulation must always be packed tightly around the ducts.

Outdoor air and exhaust air ducts in cold areas

It is recommended to insulate ducts for outdoor air and exhaust air ducts with at least 50 mm insulation. The outdoor air duct is insulated to prevent warm air in the attic from heating the fresh air in the summer. Be sure to seal the connection where the outgoing duct passes through the roof or gable to prevent condensation damage.

Insulation of ducts in heated rooms

Genvex recommends the following:

Supply air and exhaust air ducts

In a warm attic, the supply air and exhaust air ducts must be provided with 50 mm of insulation finished with aluminium foil. Supply air and exhaust air ducts routed through heated rooms in the home do not need to be insulated unless cooling, a bypass or a geothermal heat exchanger are used. In this case, the supply duct must be insulated.

Outdoor air and exhaust air ducts

In warm attics and heated rooms in the home, outdoor air and exhaust air ducts must be insulated with a minimum of 50 mm insulation. In addition, the insulation must be lined on the outside with cling film or aluminium foil to avoid condensation inside the insulation.

Contact your local supplier for advice on the national insulation guidelines.

When using a geothermal heat exchanger, it is recommended to add 100 mm of insulation to the outdoor air duct.

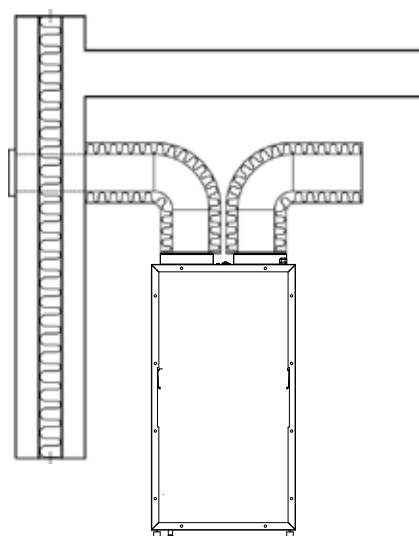

Electrical installation

ECO 275 is equipped for the external connection of 230 volt power plug, internet, display, BMS connection and Genvex accessories.



See wiring diagrams and operating instructions for the Optima 270 for more information.

In general, all electrical connections to the ECO 275 must be made by an authorised professional.

Important!!

For functional and safety reasons, the unit must be connected to a socket with grounding matched to the plug connection.

Control and calibration of the system

To achieve optimal operation of the system, it must be calibrated using specialist ventilation measuring equipment. If it is desired to put the system into operation before calibration, the following approach can be taken:

Before putting the system into operation

1. Check that the Genvex unit is correctly mounted and that all the ducts are properly insulated.
2. Check that the door can be opened so that it is possible to service and maintain the unit.
3. Check that the filters are clean (they may be dirty after installation).
4. Set all supply air valves so that the valve closest to the unit is opened 3 turns from the closed position and the outer one is opened 8 turns from the closed position. The intermediate valves are opened between 4 and 7 turns, depending on how close they are to the unit.

The system can now be put into operation and run until the system is calibrated using specialist ventilation measuring equipment.

Optimal initial calibration of the system

Genvex recommends that the ventilation unit should be calibrated by an authorised Genvex dealer before it is put into operation.

Before starting the initial calibration, check that the 4 points in the section on control and calibration of the system have been performed. Then start the unit: Set the initial basic ventilation value, which is speed 2. To reduce energy consumption as much as possible, first adjust the main air flows to the desired air flow by adjusting the speed of the fans via the control panel. Then adjust the supply air and exhaust air valves with air measuring equipment (during the initial calibration of the valves, remember to lock them and to turn the baffle plate in the supply air valves so that the air blows in the right direction).

Check the main air volumes again and fine-tune the main air volumes using the outdoor air and exhaust air valves (being sure to lock the position of the valves after the initial adjustment).

SYSTEM MAINTENANCE

Remember to switch off the power by removing the device plug in ECO 275 or at the socket before opening the unit or changing the filter. Note - it may be difficult to reach the device plug on the unit when the ducts are installed and insulated.



Filters

When the filter timer reaches the set value for a filter change, this will appear in the text in the Optima Touch display or in the Genvex app, or be indicated by a yellow flashing light in Optima Basic. This means that the filters must be replaced/cleaned.

Stop the system by removing the device plug in ECO 275 or at the socket. Open the filter plugs and remove the filters. Once the filters have been cleaned/replaced, insert the clean filters and click the filter plugs onto the cabinet again. Reconnect the 230V power.

The filter alarm can now be reset via the display or the app. The system then returns to normal operation. If you want to replace the filters using a different time interval, this can be adjusted in the user menu.



 Do not vacuum or clean at high air pressure. This will damage the filter!

Access to internal parts

Important: The disassembly of the front plate and the exposure of conducting/moving parts may only be performed by a professional.

To access internal parts of the ECO 275, remove the front plate.

1. Remove the screws from the front plate to access internal parts.



2. Remove the bracket with the sensor mounted in the exchanger



3. Disassemble the exchanger by pulling on the belt gently



4. Remove the fan housing (and, if included, built-in preheating surface) by gently pulling the fan housing with pliers.



5. Disassemble the bypass by releasing the bypass flap with the magnet shown. After removing the two screws as shown, the bypass motor can be removed.



6. Disassemble the level gauge by removing the two screws as shown (accessory).



Preheater

Inspect the preheater for dirt and make sure that the connectors and the heater are intact.



Supply air and exhaust air valves

Clean the valves by wiping them with a dry cloth. Make sure that the valve does not rotate, thus causing a change in the air volume.

Important!

When reinstalling the front plate on the ventilation unit, do not use power tools to tighten the screws, as this may result in damage to the threaded connections. Carefully tighten all the screws until the front plate is firmly fitted on the cabinet of the ventilation unit.

Fan

Check the two fan wheels for dirt. If they are dirty, they can be cleaned with a brush, bottle washer or similar.

Recommended maintenance intervals

Component	Action	Interval
Filter	Replaced at regular intervals so that full efficiency of the unit is achieved.	3-6 months
Fans	Fans must be cleaned with a soft brush to ensure operational safety and efficiency.	12 months
Countercurrent heat exchanger	Clean with water	12 months
Gaskets in general	Check gaskets on the unit and make sure they are intact	12 months
Supply air and exhaust air valves	Check for dirt inside the supply air and exhaust air valves. Clean as needed. Check that the valves have the desired setting in relation to air volumes.	12 months
Air intake	Check for dirt and grime inside the air intake and exhaust air vents and clean as needed	12 months
Ventilation ducts	Check the cleanliness of ducts and clean as needed.	10 years

SPARE PARTS

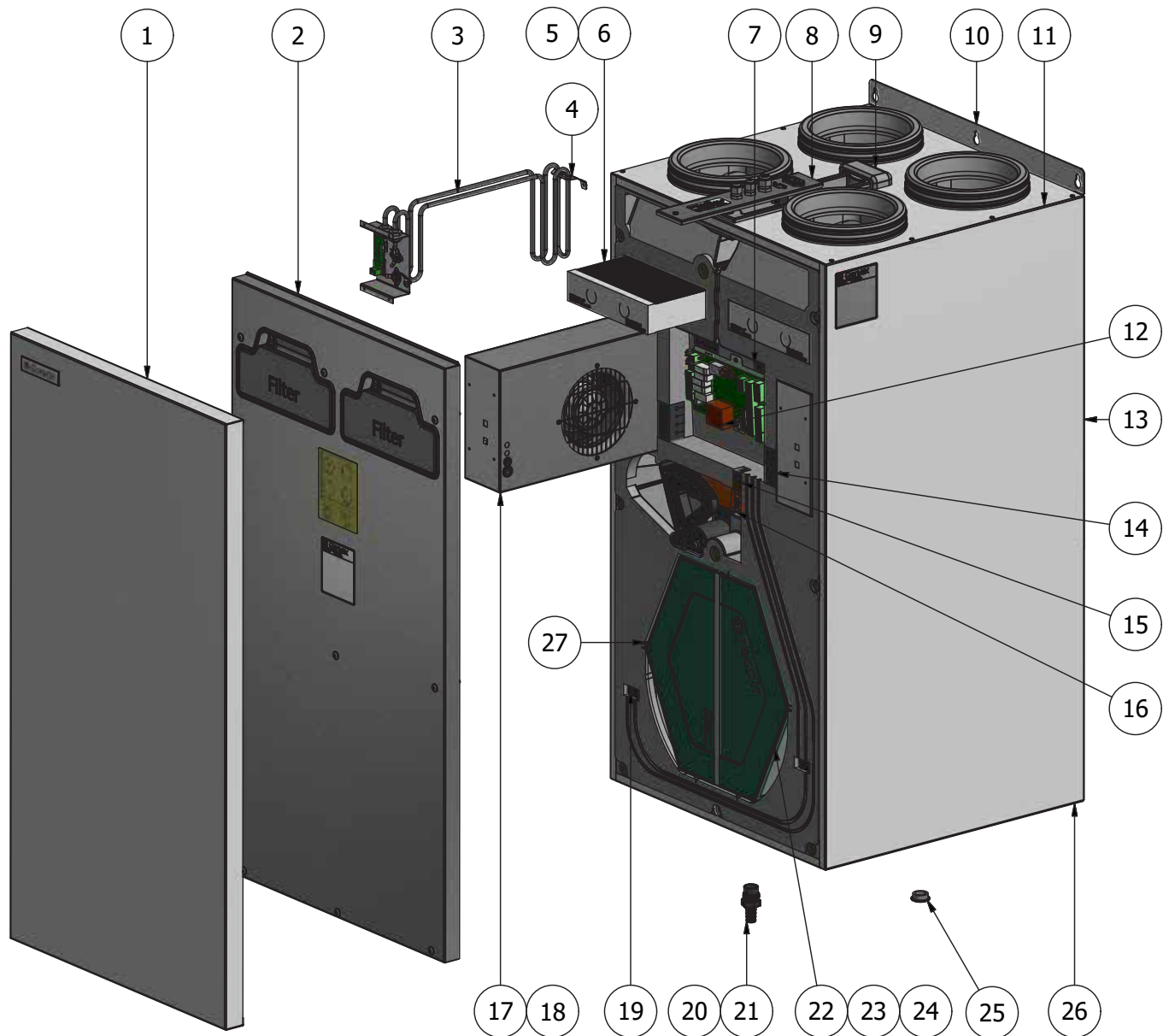

No.	Item no.	Description
1	072022	Front cover - Ral. 9016
2	072037	Assembled front door
3	072015	1200 W. Preheater (option)
4	072045	Bracket for preheater
5	072009	Filter 50 mm F7
6	072008	Filter 50 mm G4
7	072029	Gasket - 3 cable
8	072016	I/O module
9	072000	EPP Cabinet
10	072030	Mounting brackets
11	072020	Top plate - Ral. 9016
12	069875	OPTIMA 270 Print
13	072019	Side plate - Ral. 9016
14	072026	Gasket - 4 cable

No.	Item no.	Description
15	072028	Gasket - 1 cable
16	060536	Bypass motor
17	072010	Assembled fan housing
18	060559	EC fan
19	072027	Gasket - 2 cable
20	072035	O-ring for drain connection
21	072034	Drain connection
22	072014	Counterflow exchanger 400 mm.
23	069807	Sensor clips for exhaust air
24	072024	Gasket for counterflow exchanger
25	072040	Blind plug M25x1.5
26	072021	Bottom plate - Ral. 9016
27	072046	Sealing strips - 6mm - L 405 mm

TROUBLESHOOTING

Safety thermostat in electric heater

If a fault occurs in the built-in electric heater, the safety thermostat will switch off the unit. The electric heater is equipped with a fire thermostat, which automatically shuts off the power if the temperature exceeds 40°C. When the temperature falls, the heater switches on again automatically.

As an extra safety feature, there is a built-in thermal fuse which triggers disconnection if the temperature exceeds 60°C.

Reconnection must be executed manually via the red button indicated in the pictures below.

The red reset button can be activated through the fan housing with a screwdriver. REMEMBER to disconnect the power from the system!



Reset button

System not running

- Fuse in electric panel has blown, no voltage in the system.
- One of the fuses in the system's control board has blown.
- Loose cable, no voltage to the unit.
- Incorrectly set weekly program.
- Filter timer has switched off the system.

No supply air

- Defective supply air fan.
- Clogged supply air filter.
- Outdoor air grille clogged with dirt and leaves during autumn or snow and ice during winter.
- Fuse on control board has blown.
- Unit is defrosting (supply air fan runs at reduced speed)
- Incorrect setting of Optima controls

No exhaust air

- Defective exhaust fan.
- Clogged exhaust filter.
- Fuse on control board has blown.

Cold supply air

Fault

- Heat exchanger is clogged.
- The exhaust fan is defective.
- The exhaust air filter is clogged.
- The electric preheating surface is disconnected from the overheating thermostat (only for systems with an electric preheating surface are installed).
- Air in heating pipe, defective thermostat/motor valve, incorrect setting of control panel.

If none of the above errors are relevant, contact:

- During the warranty period (0-2 years), the installer from whom the unit was purchased.
- After the warranty period (2 years ->), the installer from whom the unit was purchased or the Genvex Customer Centre by calling 7353 2700.

Please have the data from the type plate ready (silver plate on the unit).

Alerts

See Optima 270 operating instructions.

ELECTRICAL DIAGRAM OPTIMA 270 - RIGHT

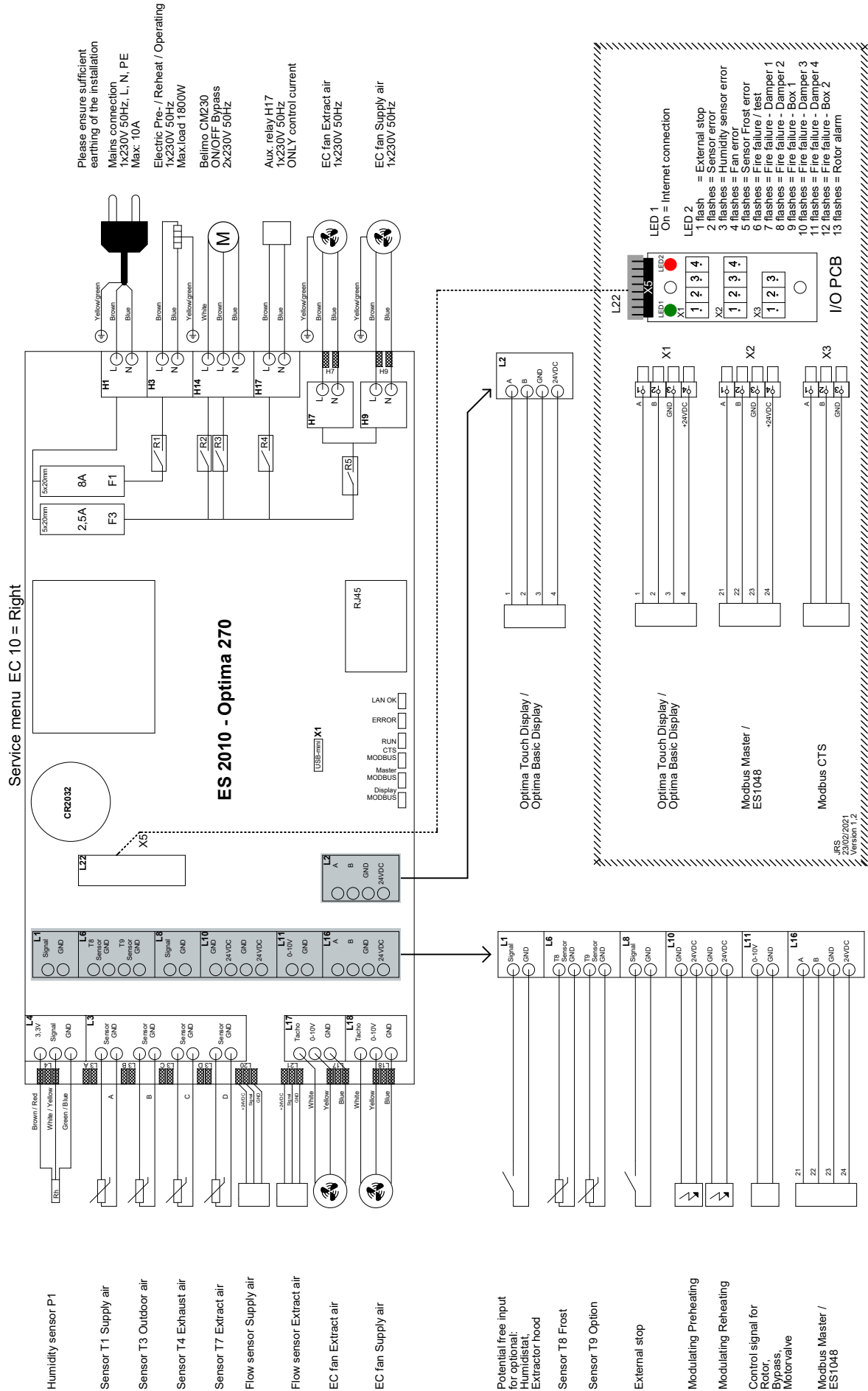

ELECTRICAL DIAGRAM OPTIMA 270 - LEFT

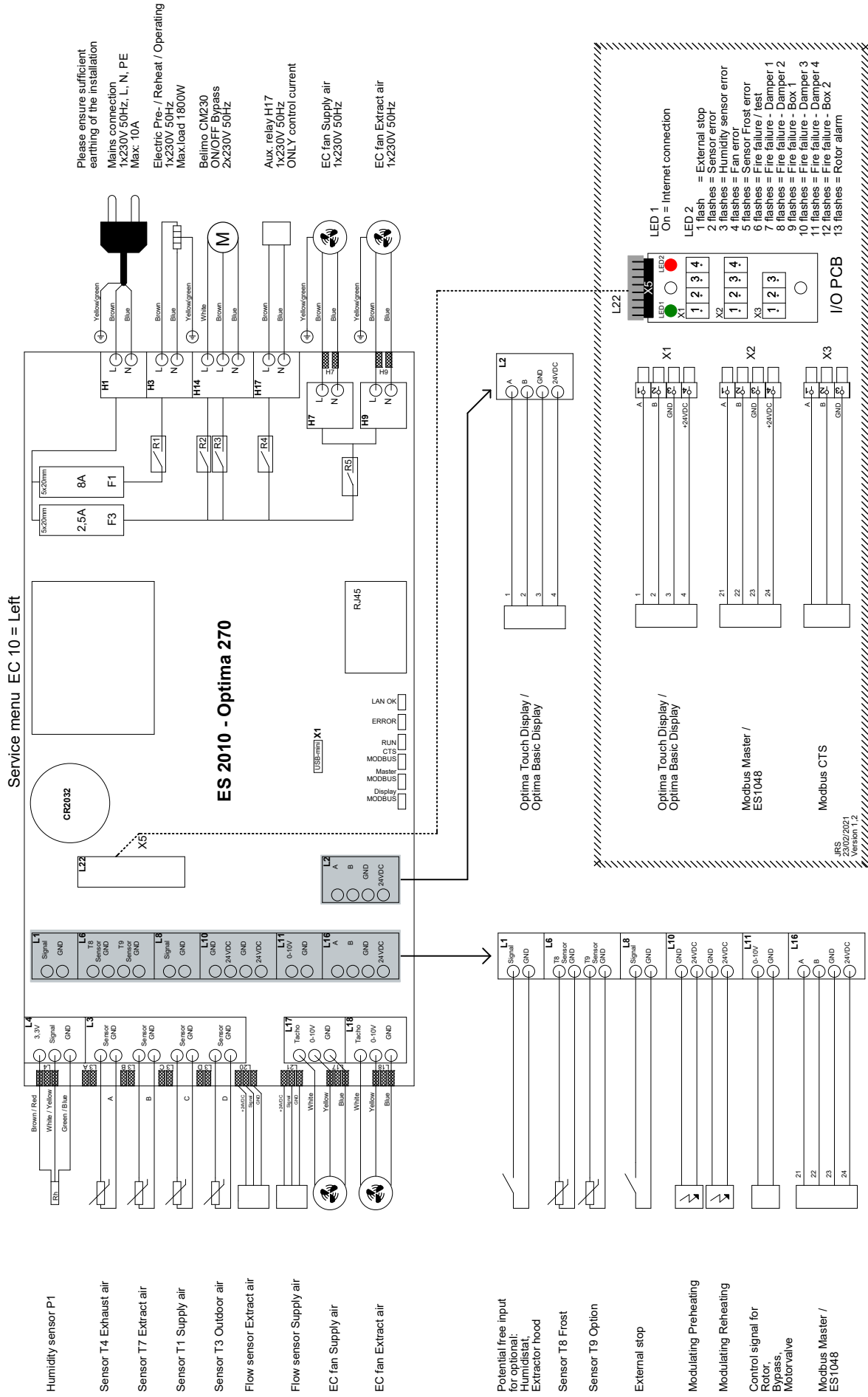

DECLARATION OF CONFORMITY

The declaration of conformity can be found on our website: www.genvex.com

DE-INSTALLATION INSTRUCTIONS

For further information on dismantling components with a view to disposal and recycling, see illustrations under “System maintenance”

THE AIR WE BREATHE

All
Genvex
systems are
rated with
energy label
A

The original Genvex units are assembled by skilled and experienced technicians and have a lifetime that in many cases is measured in decades. The units are approved by all applicable standards and are easy to operate and service. Last – but not least all Genvex systems are developed with focus on compact dimensions and ease of installation and can be integrated discreetly in all types of homes.

We are part of the NIBE Group – a family of companies that specialize in supplying hot water, heating and home comfort to homeowners worldwide.

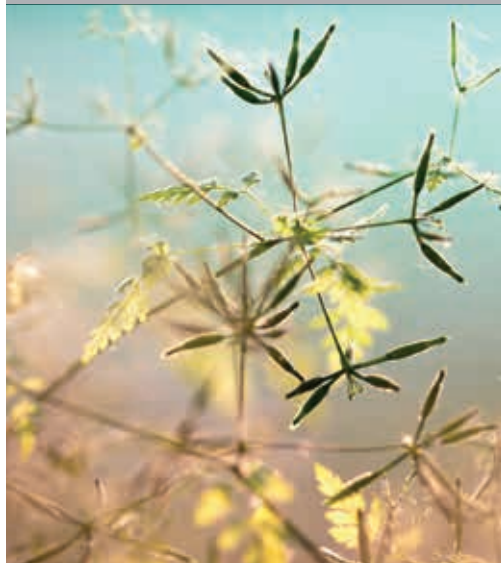

Genvex – The original Danish Ventilation System

Genvex is a genuine Danish original. We invented the ventilation system more than 40 years ago, and we are still ahead of the pack when it comes to development and production of the strongest and most durable ventilation system.

Our unit is working in thousands of homes providing fresh clean air – free of pollen, dust and harmful particles. This helps to strengthen the health of the house and to make the indoor environment healthy and comfortable for lots of families. At the same time, our system is an important element when it comes to saving energy in homes and in society as a whole – in fact you can recover up to 95% of the heat energy with a Genvex system.

Please visit www.genvex.com to see a list of our distributors

