

ECO 300



- Lightweight construction for easier installation
- Compact and energy efficient
- Low heat loss due to high thermal insulation

ECO 300 is a ventilation system with heat recovery with a highly efficient counter flow exchanger that has a temperature recovery rate of up to 94% and fans with energy-saving EC motors. ECO 300 is typically used in homes where the emphasis is on comfort and low energy consumption.

ECO 300 stands out by being particularly energy-optimised. The ventilation system is particularly suitable in unheated rooms such as unused roof spaces due to the high degree of thermal insulation. The system comes with G4/Coarse filters on the outdoor air intake and exhaust as standard (M5/F7 filter available as an add-on accessory).

ECO 300 can be equipped with a heat exchanger made from PET (plastic) or an enthalpy heat exchanger where, in addition to heat recovery, it is also possible to recover moisture from the exhaust air in the home.

The system comes with Optima 270 control:

- Passive comfort cooling with fully automatic 100% bypass.
- Reduced energy consumption by means of modulating humidity control and calendar programming.
- Connection of electric preheating or post-heating surface, which adjusts the temperature according to requirements.
- Can be connected to a BMS system via Modbus communication.
- Integrated RJ45 connection to connect the system to the cloud.
- Can be used without a display or with the option to connect one of two display types (Basic/Touch).
- Built-in data logging and the option of remote monitoring.

Please note that displays are sold separately.



Dimensional sketch

Dimensions in mm

Right-facing

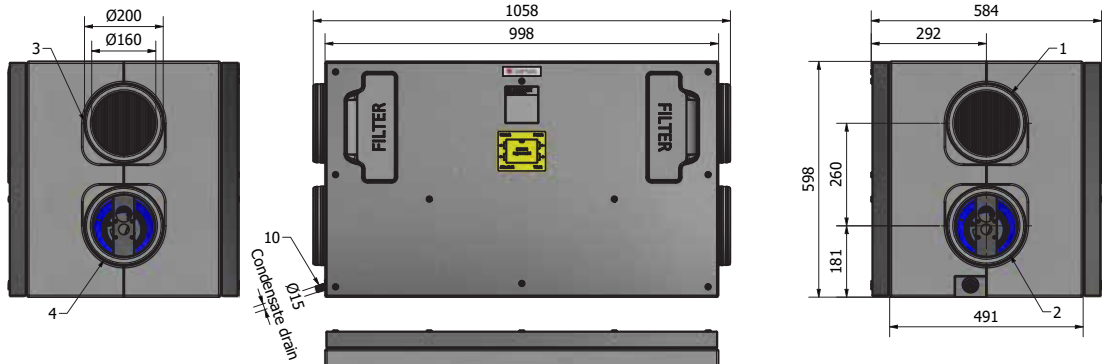

1. Outdoor air
2. Exhaust air
3. Extract air
4. Supply air
5. Heat exchanger
6. Supply air fan
7. Exhaust fan
8. Filter outdoor air
9. Filter exhaust air
10. Condensate drain
11. Electrical connection
12. Bypass

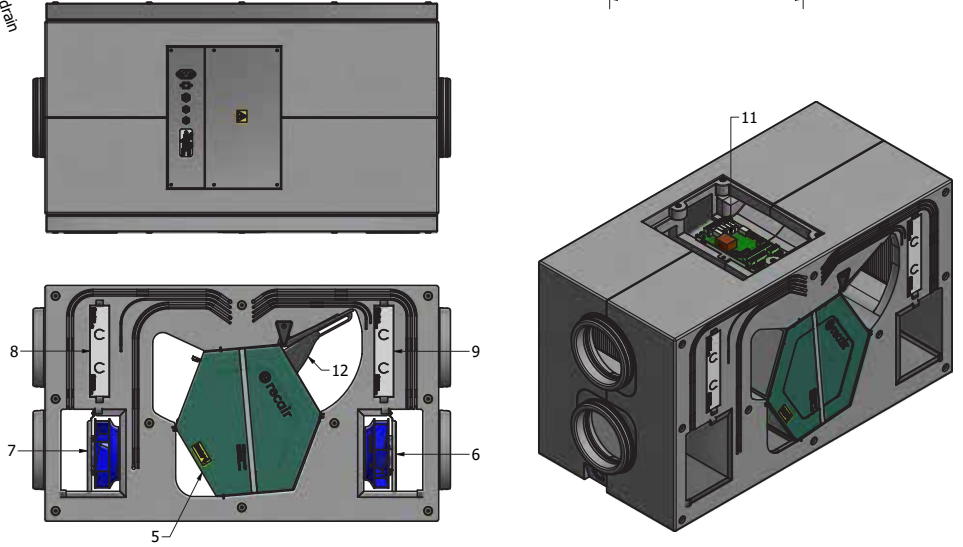

Left-facing

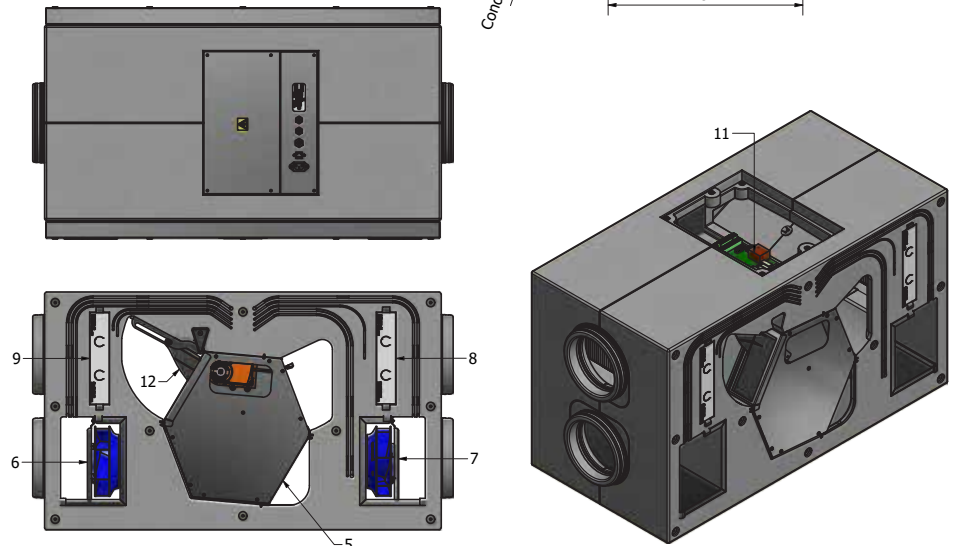
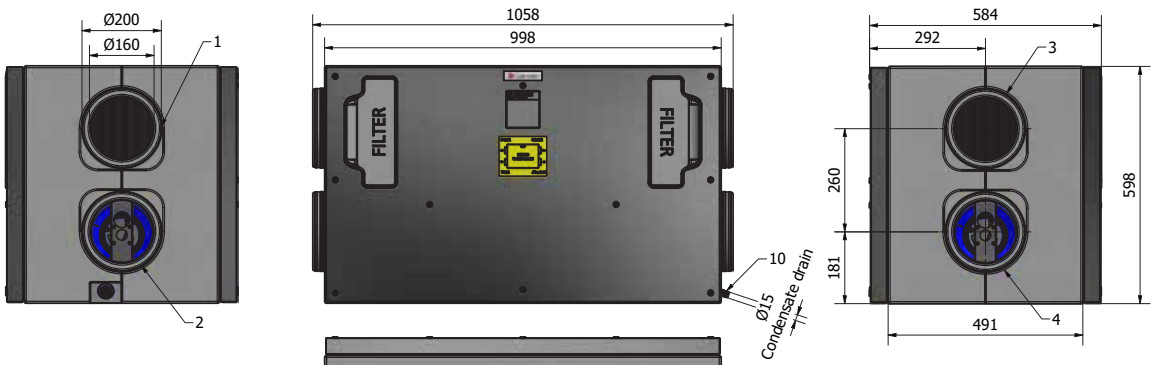

Technical data

ECO 300	
Electrical connection	1 x 230V + N + PE 10 A, 50 Hz
Fans	Ø180 mm backward curved blades
Motor	EC motor with integrated electronics
Insulation class for fan	B
Fan protection class	IP 44
Fan speed	3,570 RPM
Absorbed power (max. per motor)	90 W
Power consumption for fan	0.9 A
Dimensions (L x W x H) incl. connecting pipes	1058 x 584 x 598 mm
Cabinet	EPP 40 mm
Duct connection	External Ø200/internal Ø160
Front/rear cover	Exterior: Galvanised sheet metal 0.9 mm Interior: EPP 40 mm/PE gasket
Installation	Horizontal installation on the floor - right/left.
Counter flow heat exchanger	PET plastic and enthalpy
Working range, counter flow exchanger	-20°C to +50°C
Condensate drain	15 mm ABS
Filters	G4/Coarse (outdoor air/exhaust air) - F7/ePM1 (accessory)
Sound pressure level (Lp) at 1 m.	55 dB(A) @ 311 m³/h, 100 Pa
Weight	33 kg with front/rear cover and 20 kg without front/rear cover
Degree of thermal insulation	U=0.87 w/m²xK (class T2 according to EN1886)
Energy class	A

Capacity

The capacity lines are based on an average supply air and exhaust air volume in a system. The curves indicate the average external pressure available at a given air volume. Power consumption for the control is not included in the SFP value (approx. 6 Watt).

The capacity lines do not change when using an enthalpy heat exchanger instead of a plastic heat exchanger.

SFP factors ECO 300 - measured according to EN13141-7 (Coarse/ePM1)

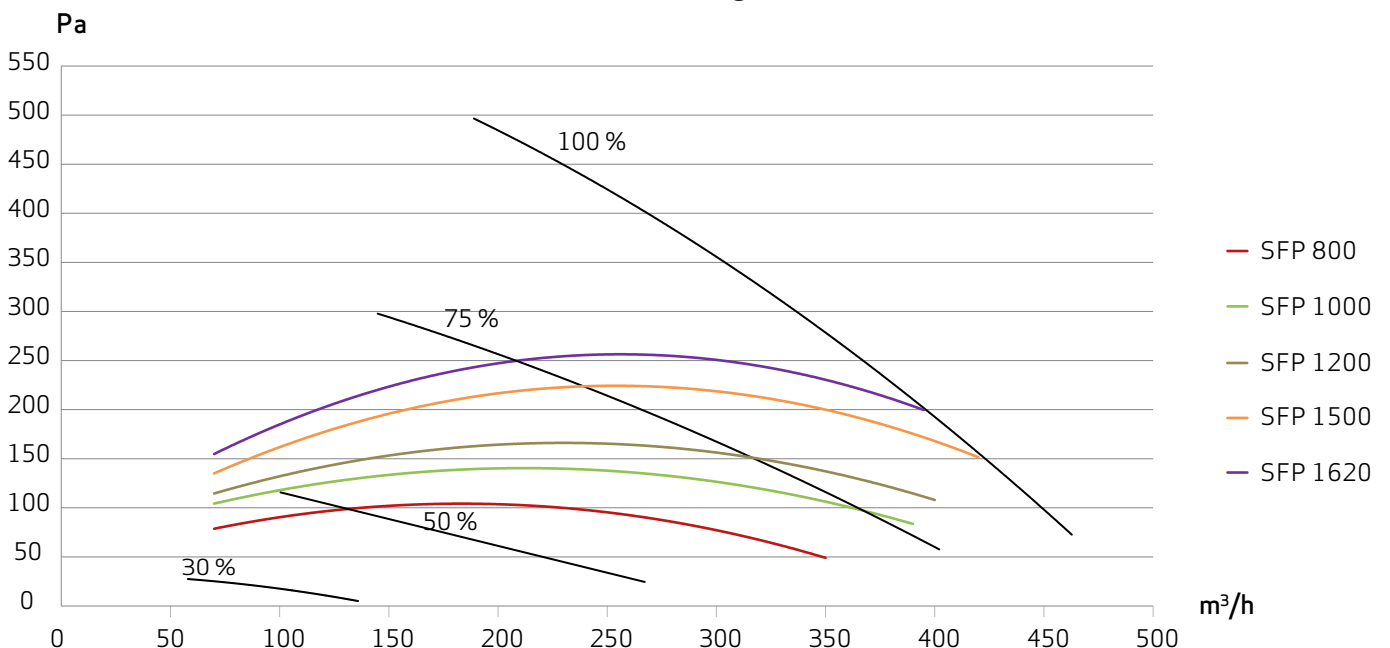

Power consumption

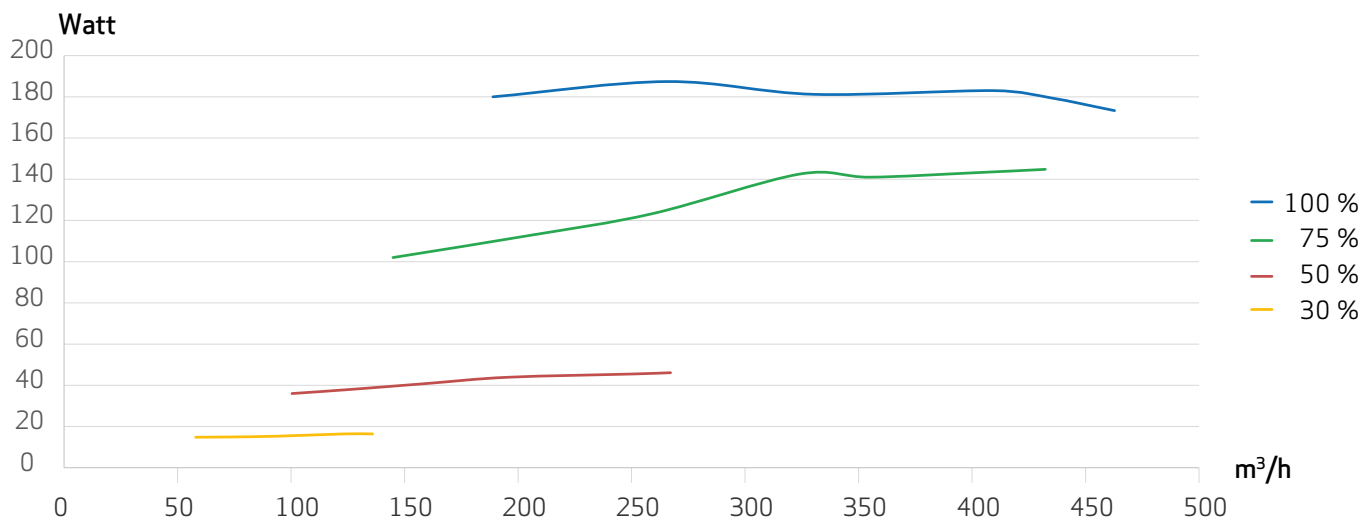

Temperature efficiency

“Dry” temperature efficiency in accordance with EN 13141-7 and identical air flow on the outdoor air and exhaust air side. This does not account for any ice that may accumulate on the heat exchanger at low outdoor temperatures.

Temperature efficiency in accordance with EN13141-7

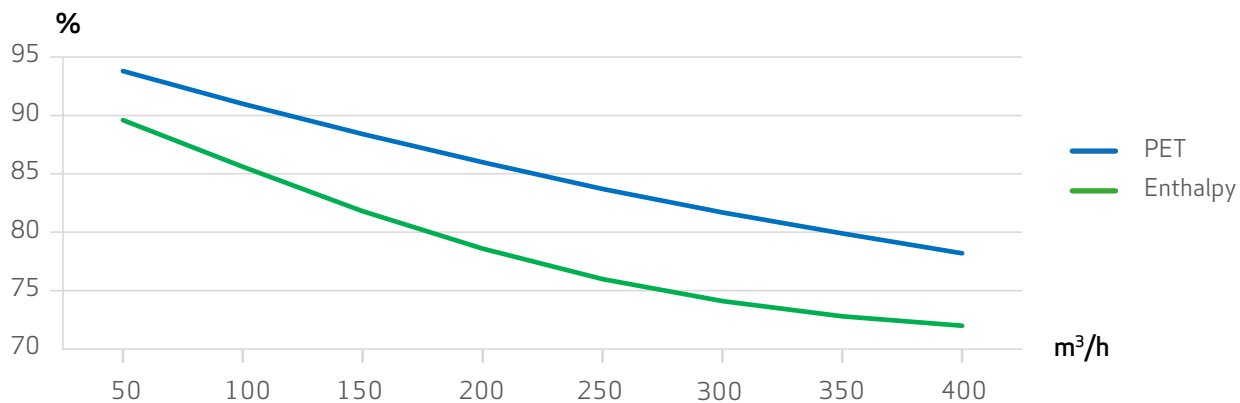

Automatic control

ECO 300 comes with Optima 270 automatic control. The Optima control features a factory setting that makes it possible to put the system into operation without first having to set the system's operating parameters. The factory setting is only a basic setting, which can be changed according to your operational wishes and needs for your home.

ECO 300 can be delivered with the following add-ons:

- Genvex Fire Automation.
- Water-based post-heating surface incl. motor valve for installation in ventilation duct.
- Electric pre-heating surface and electric post-heating surface for installation in ventilation duct (pre-heating surface can be delivered factory-mounted and integrated into the machine).
- Wireless demand control kit that measures individual rooms (CO₂).
- Level switch for condensate.
- Optima Basic or Optima Touch control panel.

Control panel



Speed

With this function, it is possible to set the fan speed in steps 0-1-2-3-4.



Extended operation

With this function, it is possible to set the timer for forced operation for between 0 and 9 hours.



Lock display

This function locks the display for 5 seconds. Typically used when wiping down the display



Main menu

With this function, it is possible to enter the main menu, where you will find the following sub-items: calendar, user menu, display, information menu and service menu.



Information

With this function, it is possible to get a good overview of the system's current operating condition, e.g. temperature, fan setting, relay status/functions, alarm, timer, etc.



Temperature

With this function, it is possible to set the desired temperature.

Contact us

