

INSTALLATION MANUAL



ECO 360 R

Mechanical ventilation with passive heat recovery

TABLE OF CONTENTS

Safety information	3
Functional description	4
Installation	5
Wall mounting (vertical connections).....	5
Floor mounting (vertical connections).....	6
Horizontal mounting of the unit (horizontal connections)	6
Dimensional sketch.....	7
Duct connection	8
Duct system.....	10
Insulation of ducts in cold attics	11
Insulation of ducts in heated rooms	11
Post-heating of supply air	11
Electrical installation	12
Control and commissioning of the system.....	12
Optimal initial commissioning of the system.....	12
System maintenance	13
Filters.....	13
Access to internal parts.....	14
Cleaning and inspection of rotary heat exchanger.....	15
Post-heating surface.....	16
Fan	16
Supply air and exhaust air valves	16
Recommended maintenance intervals	17
Spare parts	18
Troubleshooting	19
Safety thermostat in electric heating surface	19
System not running.....	19
No supply air	19
No exhaust air.....	19
Cold supply air	19
Alarms	19
Electrical diagram Optima 270 – right	20
Electrical diagram Optima 270 – left	21
Power consumption display, control and rotor	22
Declaration of conformity	23
De-installation instructions	23

SAFETY INFORMATION

This manual also describes installation and service work to be performed by a professional.

This appliance can be operated by children aged 8 and over, by persons with reduced physical, sensory and mental abilities, and by persons with a lack of experience and knowledge, provided they are supervised or have received guidance on using the appliance in a safe way and understand the dangers involved. Children must not play with the appliance. Cleaning and user maintenance must not be performed by children without supervision.

Subject to design changes.

Labelling

The CE mark represents Genvex's assurance that the product complies with all regulations laid down for the product in accordance with relevant EU directives. The CE mark is mandatory for most products sold in the EU, irrespective of where they are made.

FUNCTIONAL DESCRIPTION

The ECO 360 R is a ventilation system for comfort ventilation of homes.

The unit is equipped with a high-efficiency rotary heat exchanger which recovers both heat and moisture as needed – and thus ensures low energy costs and an optimal indoor climate with reduced risk of the home drying out in winter.

Due to the properties of the rotary exchanger technology, no condensation is discharged from the system, which means condensate drainage is not necessary. Similarly, a balanced air volume can be maintained during defrosting of the rotary exchanger, as the speed of the rotor is fully modulating and reduced to a level necessary for efficient defrosting. During defrosting, an integrated modulating electric reheater ensures that the supply air temperature is maintained at an appropriate level.

The unit can be supplied with integrated flow sensors, ensuring easy commissioning and a constant air volume in all conditions (flow sensors are accessories and ordered separately).

The ECO 360 R is designed for indoor installation, but – if specific country requirements allow – it can also be used outside the building envelope in areas protected from wind and weather.

NOTE

When installing outside the building envelope, condensation may occur on the outside of the system under certain conditions. To avoid condensation, it is recommended removing the steel front so that hot, moist air cannot build up under the front lid.

INSTALLATION

IMPORTANT!

The unit may only be used in connection with an electrical installation executed properly with grounding. It must also be ensured that the earth connection of the electrical installation is matched to the earth plug of the unit.

These instructions must be followed. If the installation is not executed in accordance with these instructions, KVM-Genvex cannot be held liable for any further damage that is unrelated to the Genvex unit.

KVM-Genvex A/S always recommends careful planning of the installation space for your Genvex product in relation to the location of living spaces. As this is a technical product that contains fans and/or a heat pump, in rare cases, and in combination with inappropriate installation conditions, it may cause unsatisfactory noise or vibration nuisance. As a general rule, it is always recommended installing the technical system so that it is not located in the immediate vicinity of a bedroom. Furthermore, when securing the Genvex unit to the building structure, it is recommended attaching it to a heavy structural component such as concrete. It should also be ensured that no sound or vibrations can be transmitted through materials in contact with the technical system. If there is a risk of propagation of noise and vibrations, further installation of vibration-damping material and sound-damping of installation rooms are recommended.

Wall mounting (vertical connections)

Before starting the installation of the ventilation unit

Make sure that the wall used to hold the ventilation unit is built in such a way that it is able to support the weight of the unit. In addition, the wall must be straight and plumb.

1. Before attaching the mounting bracket to the wall, ensure that the bracket is in the correct position and that the necessary space and service conditions are available. Place the mounting bracket level and mark the positions of all 4 screw holes.



2. Attach the bracket to the wall using screws in all 4 mounting holes.



3. Mount the ventilation unit by hanging it on the mounting bracket. The recess on the back of the unit is intended for this.



Once the ventilation unit has been properly attached to the mounting bracket, lock the unit in place by inserting the locking screw into the locking hole. The supplied safety screws must be fully tightened!

Floor mounting (vertical connections)

1. The 4 supplied adjusting legs are screwed into the threaded holes in the base of the unit.
2. The adjusting legs can be adjusted from 27-35 mm to level the unit.

Horizontal mounting of the unit (horizontal connections)

Please note :

Horizontal installation is only allowed if ECO 360 R is ordered as a horizontal configuration.

Note - for this installation method, the filter on the right side must be attached to the filter frame (e.g. using elastic straps as shown in the picture below) so that the filter is held in place and ensures 100% filtration.

Please note that this type of installation of the unit will require particular focus on servicing and accessibility.

1. The unit is mounted on its back on a vibration-damping surface - with service access from above as shown in Figure 3. C.



Figure 1. Adjusting legs

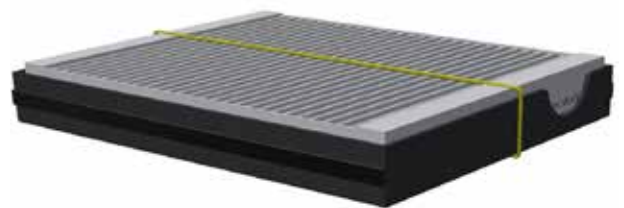

Figure 2. Filter in frame with elastic straps

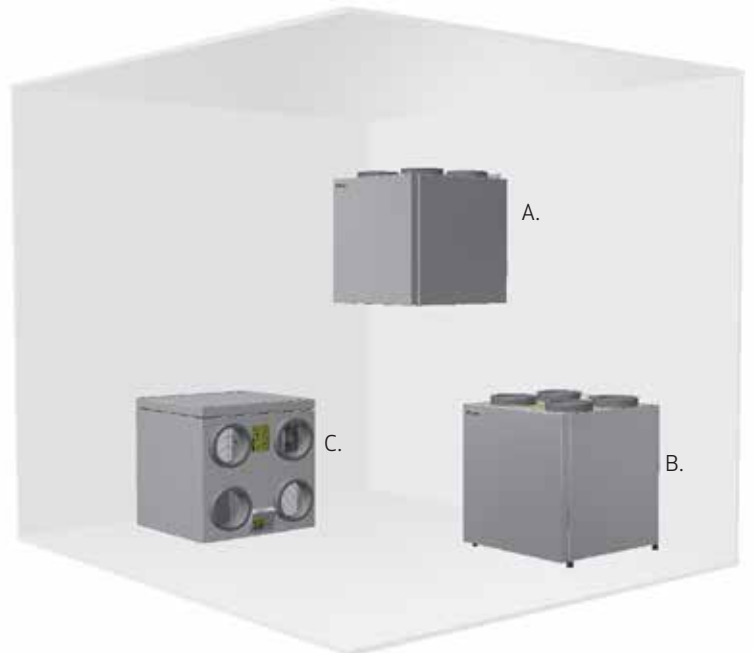

Figure 3. Installation methods - ECO 360 R

A. Wall-mounted

B. Floor-standing

C. Horizontal (Note: Horizontal installation is only allowed when ECO 360 R is ordered as a horizontal configuration)

Dimensional sketch

In order to allow access for servicing and maintenance, there must be a clearance of at least 600 mm in front of the ECO 360 R

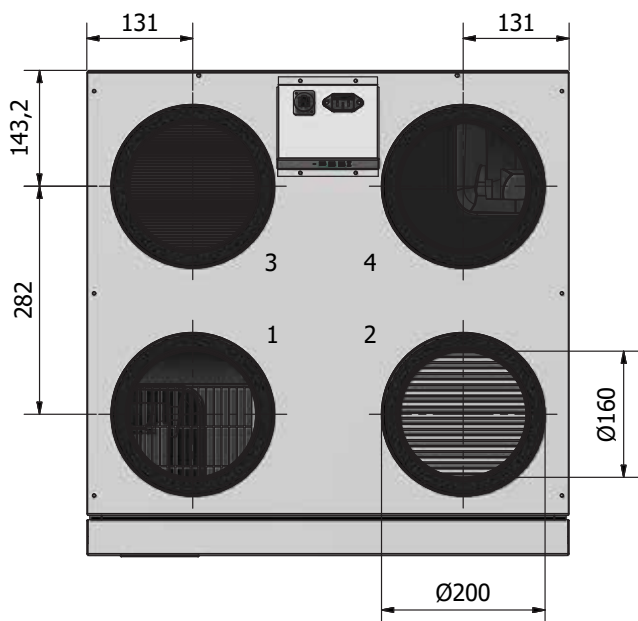
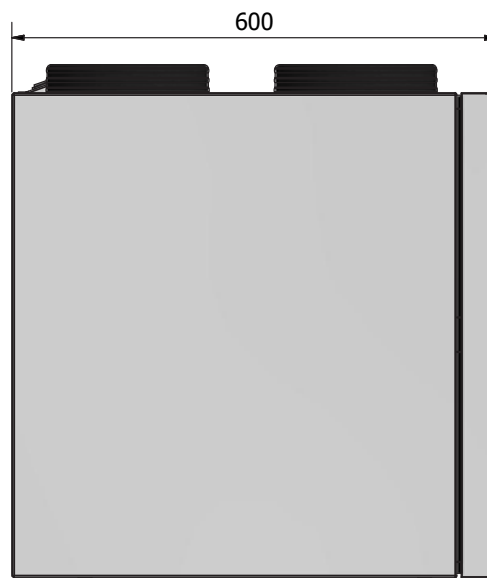
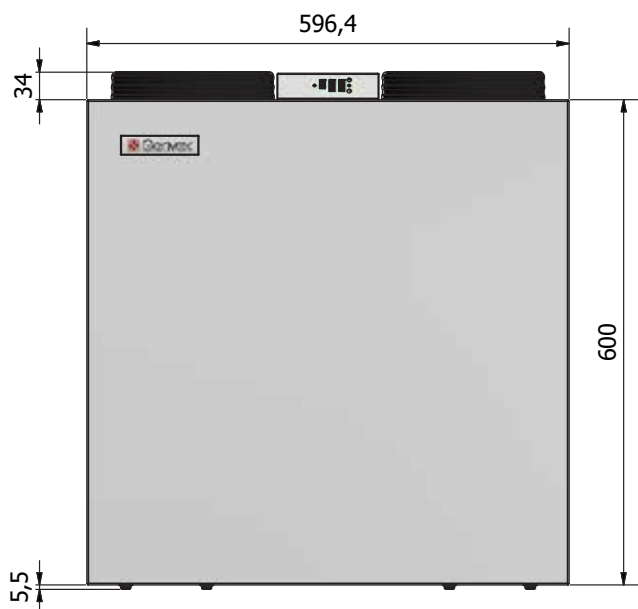

Right-hand version

1. Discharge air
2. Extract air
3. Outdoor air
4. Supply air

Left-hand version

1. Supply air
2. Outdoor air
3. Extract air
4. Discharge air

Duct connection

At duct connectors, a yellow sticker has been affixed indicating which ventilation ducts are to be connected to the various connectors.

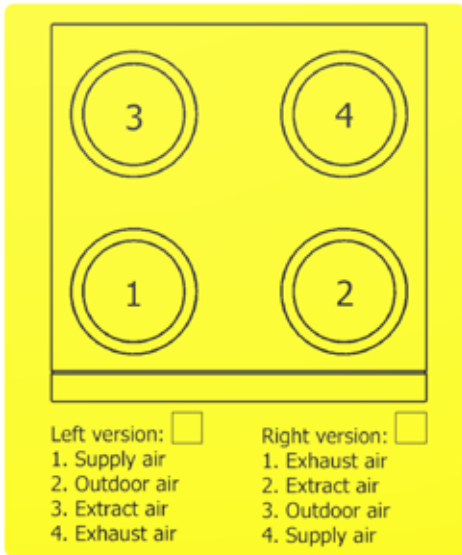

Note that the ECO 360 R is available in a right-hand version (characterised by the reheater being located in the supply air to the right of the unit) and a left-hand version (characterised by the reheater being located in the supply air to the left of the unit).

It is possible to convert a right-hand unit into a left-hand unit and vice versa by relocating the humidity sensor + exhaust sensor and post-heating surface. For more details on conversion, contact your Genvex sales representative.

ECO 360 R Right-hand

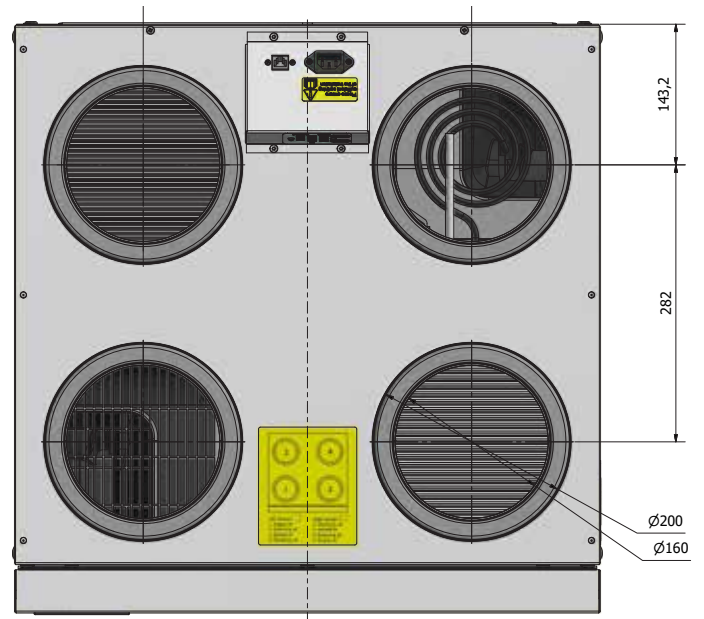

ECO 360 R Left-hand

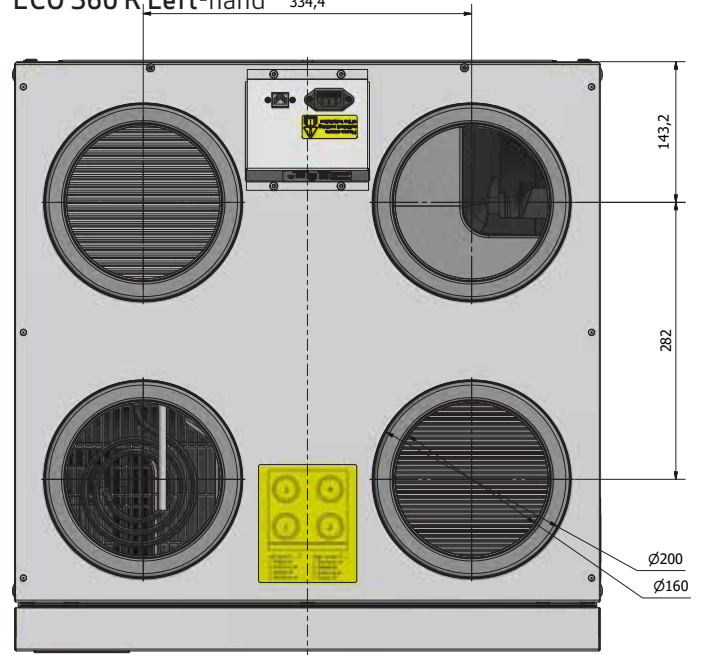

To start the duct installation, it is recommended using 4 x Ø160 mm nipple connectors with double sealing lips.

Alternatively, a Ø200 mm spiro pipe can be used, which is connected directly to the outside of the ECO 360 R connector.





Duct system

It is recommended that the duct system should be made of spiral-folded pipes assembled with fittings with rubber ring seals so that you get a tight and durable duct system. To achieve a satisfactorily low noise level from the unit, sound locks must always be installed on the supply air and exhaust air duct system between the unit and the first supply air and exhaust air fittings.

It is recommended that the air flows in the ducts should be dimensioned at a sufficiently low level to ensure that noise from the supply air and exhaust air fittings does not occur.

When positioning outdoor air and exhaust air hoods/ gratings, it must be ensured that the two air flows do not short-circuit, thereby preventing the exhaust air from being sucked in again. It is recommended that grates should be placed on the north or east side of the house to achieve optimal comfort in homes/flats.

It is recommended that the air intake should be located on the north or east side of the house to achieve maximum comfort and minimal impact from the sun's heat.

Recommended minimum horizontal distance between air intake and exhaust: 3 metres.

Recommended minimum vertical distance between air intake and exhaust: 1 metre.

In order to connect ordinary galvanised steel ducts to the ECO 360 R ventilation unit, you must first install 4 nipple connectors in the unit's $\text{\O}160$ mm openings (double sealing lips). Alternatively, $\text{\O}200$ mm galvanised steel ducts should be placed over the EPP connectors.

The unit is now ready for direct connection of ductwork on the nipple connector. It is recommended installing galvanised angle brackets to fasten the nipple connector to the galvanised housing using self-tapping steel screws.

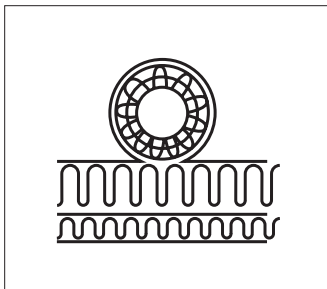
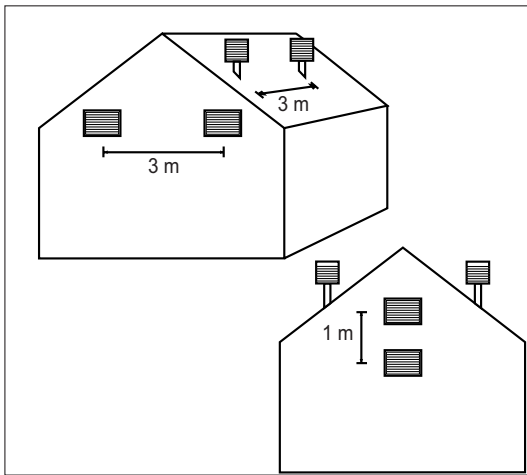

Ductwork insulation alt A

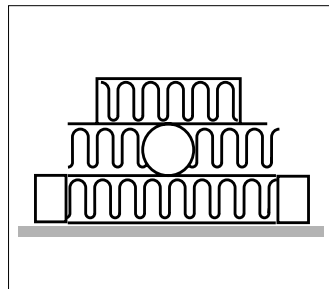

Ductwork insulation alt B

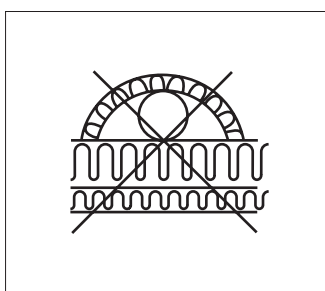

Wrong insulation

Insulation of ducts in cold attics

To benefit from the unit's high recovery potential (efficiency), the ducts must be correctly insulated.

Supply air and exhaust air ducts

In order to minimise heat loss from the duct system in cold attics, supply air and exhaust air ducts must be provided with at least 100 mm of insulation. If insulation from alternative A is used, it is recommended executing with two layers of 50 mm lamella mats with paper or foil externally and with staggered joints between the two layers. If the ducts are laid on the main beams of truss frames, alternative B can be used. The insulation must always be packed tightly around the ducts.

Outdoor air and exhaust ducts in cold areas

It is recommended providing ducts for outdoor air and exhaust ducts with at least 50 mm of insulation. The outdoor air duct is insulated to prevent warm air in the attic from heating the fresh air in the summer. Be sure to seal the termination where the outgoing duct passes through the roof or gable to prevent condensation damage.

Insulation of ducts in heated rooms

Genvex recommends the following:

Supply air and exhaust air ducts

In a warm attic, the supply air and exhaust air ducts must be provided with 50 mm of insulation finished with aluminium foil. Supply air and exhaust air ducts routed through heated rooms in the home do not need to be insulated unless cooling, a bypass or a geothermal heat exchanger are used. In this case, the supply air duct must be insulated.

Outdoor air and exhaust ducts

In warm attics and heated rooms in the home, outdoor air and exhaust ducts must be provided with a minimum of 50 mm of insulation.

In addition, the insulation must be lined on the outside with plastic or aluminium foil to prevent condensation in the insulation.

Contact your local supplier for advice on the national insulation guidelines.

When using a geothermal heat exchanger, it is recommended adding 100 mm of insulation to the outdoor air duct.

Reheating of supply air

As the rotary exchanger in the ECO 360 R cannot recapture all the heat from the exhaust air to the supply air, in the winter season the supply air will be colder than the room temperature in the home.

Especially during periods of very cold outdoor temperatures, and depending on the chosen frost protection strategy, the speed of the rotary heat exchanger can be reduced during defrosting and the supply air temperature will subsequently drop briefly.

The built-in electric reheater will ensure that a suitable supply air temperature is maintained in all conditions, provided this function is activated via the controls.

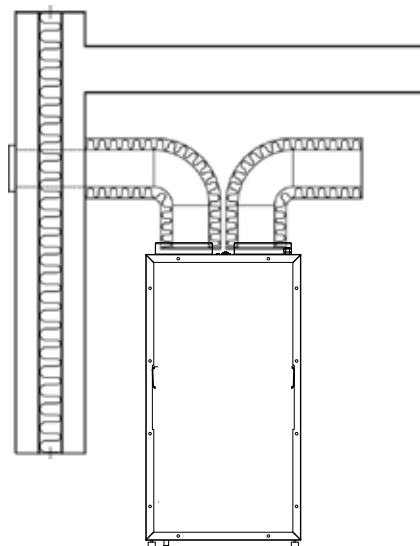

Electrical installation

The ECO 360 R comes prepared for external connection of a 230V appliance connector, internet and display, BMS connection and Genvex accessories.



See wiring diagrams and operating instructions for the Optima 270 for more information.

In general, all electrical connections to the ECO 360 R must be executed by an authorised electrician.

Important!

For functional and safety reasons, the unit must be connected to a socket with grounding matched to the plug connection.

Control and commissioning of the system

To achieve optimal operation of the system, it must be commissioned using specialist ventilation measuring equipment. If it is desired to put the system into operation before commissioning, the following approach can be taken:

Before putting the system into operation

1. Check that the Genvex unit is correctly mounted and that all the ducts are properly insulated.
2. Check that the door can be opened so that it is possible to service and maintain the unit.
3. Check that the filters are clean (they may be dirty after installation).
4. Set all supply air valves so that the valve closest to the unit is opened 3 turns from the closed position and the outer one is opened 8 turns from the closed position. The intermediate valves are opened between 4 and 7 turns, depending on how close they are to the unit.
5. It is recommended setting the integrated post-heating surface to a supply air temperature of 0-3° below the room temperature in the home so that the post-heating surface is only used to temper the supply air.

The system can now be put into operation and run until it is commissioned using specialist ventilation measuring equipment.

Optimal initial commissioning of the system

Genvex recommends that the ventilation unit should be commissioned by an authorised Genvex dealer before it is put into operation.

Before starting the initial commissioning, check that the 5 points in the section on control and commissioning of the system have been performed. Then start the unit:

Set the initial basic ventilation value, which is speed 2. To reduce energy consumption as much as possible, first adjust the main air volumes to the desired levels by adjusting the speed of the fans via the control panel.

Then adjust the supply air and exhaust air valves with air measuring equipment (during the initial commissioning of the valves, remember to lock them and to turn the baffle plate in the supply air valves so that the air blows in the right direction).

Then check the main air flows again and fine-tune them using the outdoor air and exhaust air valves (remember to lock the position of the valves after initial commissioning).

SYSTEM MAINTENANCE

Remember to switch off the power by removing the appliance connector from the ECO 360 R or at the socket (it can be difficult to reach the appliance connector on the unit when ducts have been mounted and insulated) before changing the filter or opening the unit.



Do not vacuum or clean at high air pressure. This will damage the filter!



Filters

When the filter timer reaches the set value for a filter change, this will appear in the text in the Optima Touch display or in the Genvex app, or be indicated by a yellow flashing light in Optima Basic. This means that the filters must be replaced/cleaned.

The system is stopped by removing the appliance connector from the ECO 360 R or at the socket. The filter plugs are opened and the filter drawer is pulled out. Once the filters have been cleaned/replaced, insert the filter drawer with the clean filters and click the filter plugs into place in the cabinet again. Reconnect the 230V power.

The filter alarm can now be reset via the display or the app. The system then returns to normal operation.

If you want to replace the filters with a different time interval, this can be done via the user menu.



Access to internal parts

To access internal parts of the ECO 360 R, the front plate, control board and rotary exchanger must be removed.

1. Remove the screws from the front plate to access internal parts.

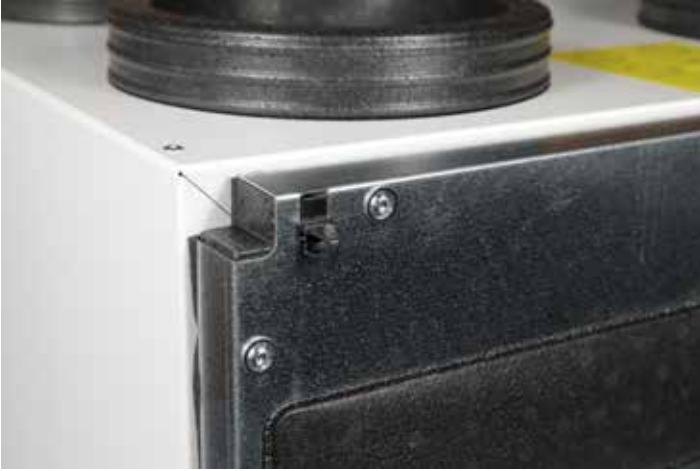

2. Remove the protective plate covering the control board.



3. Remove the 230V power cable and the control cable for the rotary exchanger motor.



4. Remove the PCB holder by removing the mounting screws.



5. Lift the control board and pull out the rotary exchanger.

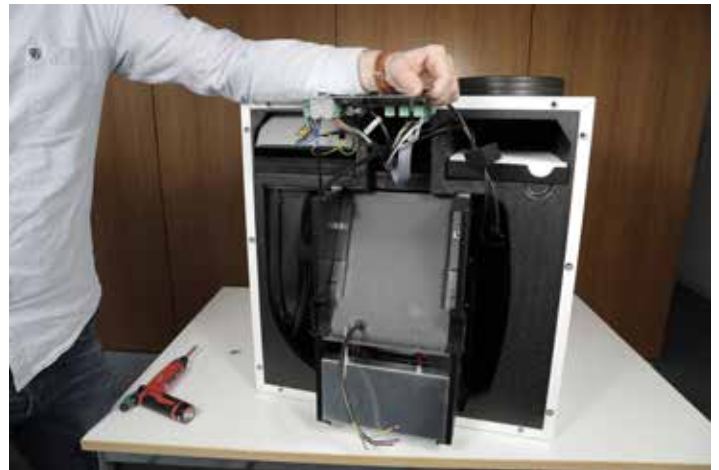

Cleaning and inspection of rotary heat exchanger

Inspect the rotary exchanger for dirt and, if necessary, use compressed air at low pressure (max. 8 bar) to blow the lamellae free of dirt.



Check brush strips and synthetic leather seals around the rotor for leaks. If seals show signs of leakage, these must be replaced.



When replacing brushes, unscrew the strips as shown in the picture below. New brushes are fitted and the strips screwed back on. BE CAREFUL not to overtighten the screws for the brush strips!



Check that the drive belt for the rotor is tight so that it does not slip in the pulley wheel of the motor. Check that the belt is intact and shows no signs of wear. Replace the drive belt as needed.

The ECO 360 R is supplied with an extra drive belt fitted - this can easily be mounted on the rotor motor by removing the transport screw on the extra belt.



Reheater

Inspect the reheater for dirt and make sure the plug connections and heater are intact.



Supply air and exhaust valves

Clean the valves by wiping them with a dry cloth. Make sure the valve does not rotate and thus cause a change in the air volume.

Important!

When reinstalling the front plate on the ventilation unit, do not use power tools to tighten the bolts, as this may result in damage to the threaded connections. Carefully tighten all the front-plate bolts until the front plate is firmly seated on the housing of the ventilation unit.

Fan

Check the two fans for dirt. If they are dirty, they can be cleaned with a brush, bottle washer or similar.



Recommended maintenance intervals

Component	Action	Interval
Filter	Replaced at regular intervals so that full efficiency of the unit is achieved.	3-6 months
Fans	Fans are cleaned to ensure operational reliability and efficiency.	12 months
Rotary heat exchanger	Make sure the lamellae are clean. Check the condition of the drive belt and seals around the rotor. Replace drive belt and seals/gaskets if necessary.	12 months
Gaskets in general	Check gaskets on the unit and make sure they are intact	12 months
Supply air and exhaust valves	Check for dirt in supply air and exhaust valves. Clean as needed. Check that the valves have the desired setting in relation to air volumes.	12 months
Air intake	Check for dirt and grime in the air intake and exhaust, and clean as needed.	12 months
Ventilation ducts	Check the cleanliness of ducts and clean as needed.	10 years
Brush strips and synthetic leather	Check that the brush strips and synthetic leather pack tightly around the rotor and that there is no leakage. Replace brushes and leather if necessary.	3 years

SPARE PARTS

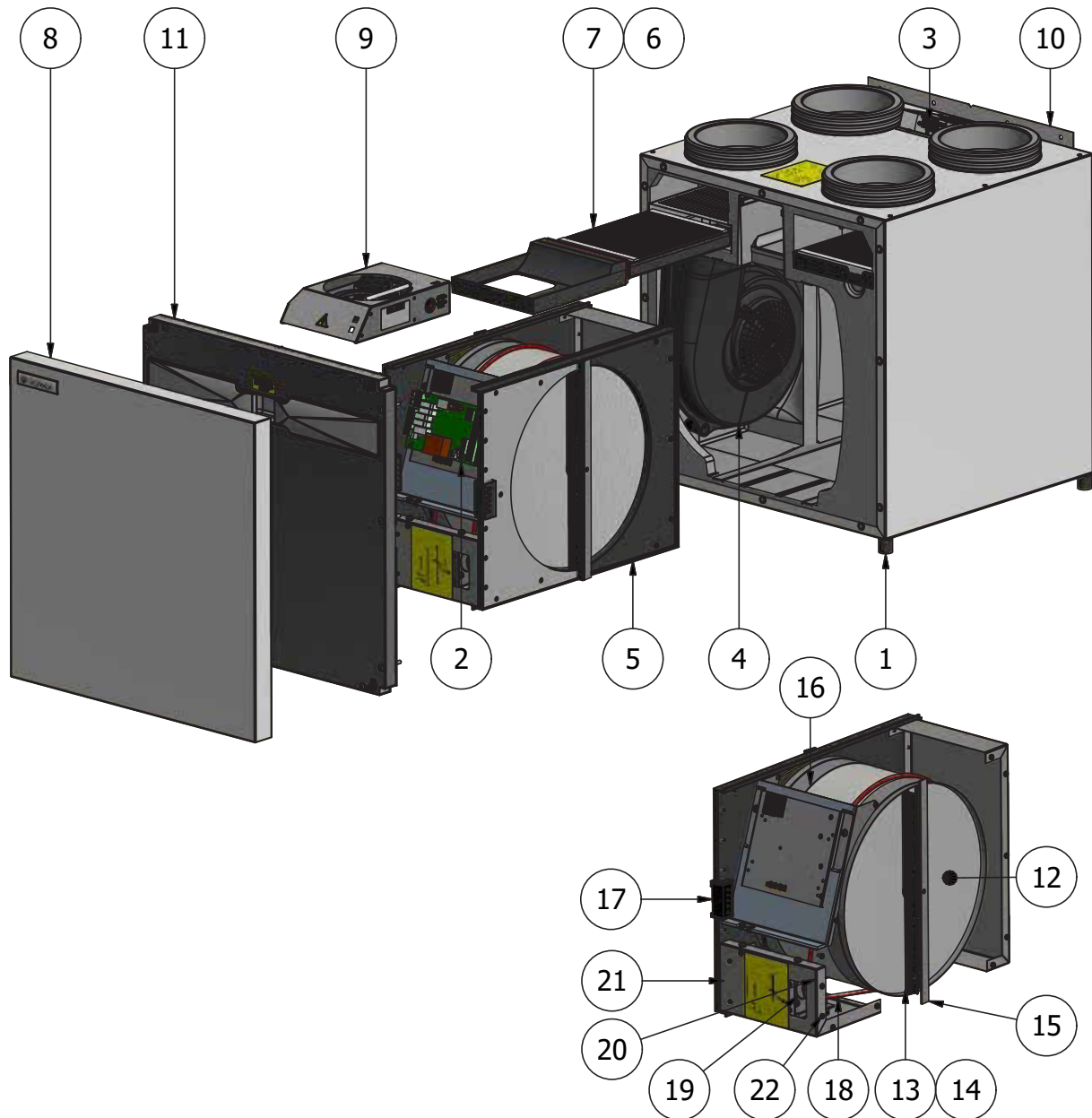

No.	Item no.	Description
1	068098	Rubber foot Ø25x25, M6x18
2	069875	Optima 270 control board
3	069876	IO control board
4	071003	Complete fan housing
5	071007	Complete rotor
6	071035	Filter G4
7	071036	Filter F7
8	071056	Front cover white
9	071063	Reheater - EAH1000R
10	071066	Mounting brackets
11	071070	Complete door

No.	Item no.	Description
12	071008	Rotary exchanger Ø375x200
13	071009	Brush TF 4.8x14 4P BK 2TFBK
14	071010	Brush strip
15	071011	Vertical gasket - rotor
16	071012	Peripheral gasket - rotor
17	071017	Wire gasket, rotor cassette
18	071021	Drive belt Ø6
19	071022	24V motor
20	071023	Pulley wheel
21	071025	Converter 230V - 24V DC
22	071069	Vibration damper Ø20x10 M6

TROUBLESHOOTING

Safety thermostat in electric heating surface

If a fault occurs in the built-in electric heating surface, the safety thermostat will switch off the unit. The electric heating surface is equipped with a fire thermostat, which automatically shuts off the power if the temperature exceeds 40°C. When the temperature drops, the heating surface automatically switches back on.

As an extra safety feature, there is a built-in thermal fuse which triggers disconnection if the temperature exceeds 60°C.

Reconnection must be executed manually via the red button indicated in the pictures below.

Left-hand system

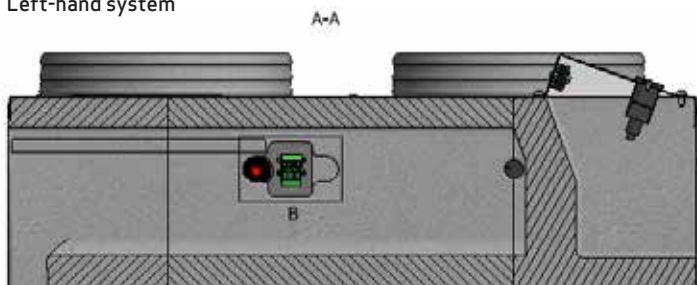

Right-hand system

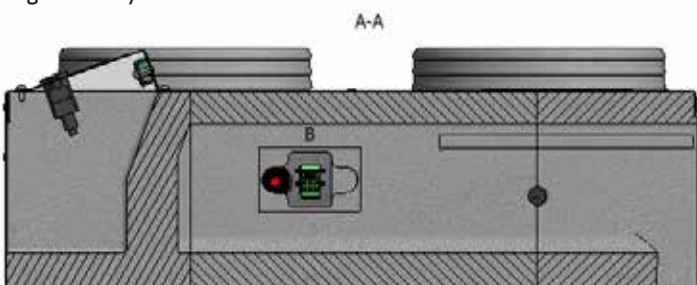

System not running

- Fuse in electric panel has blown, no voltage in the system.
- One of the fuses in the system's control board has blown.
- Loose wire, no voltage to the unit.
- Incorrectly set weekly program.
- Filter timer has switched off the system.

No supply air

- Defective supply air fan.
- Clogged supply air filter.
- Outdoor air grille clogged with dirt and leaves in the autumn, or snow and ice in the winter.
- Fuse on control board has blown.
- Unit is defrosting (supply air fan runs at reduced speed)
- Incorrect setting of Optima controls

No exhaust air

- Defective exhaust fan.
- Clogged exhaust filter.
- Fuse on control board has blown.

Cold supply air

Fault

- Heat exchanger is clogged.
- Exhaust fan is defective.
- Exhaust filter is clogged.
- The electric post-heating surface has been switched off at the overheating thermostat (only systems with electric reheater installed).
- Air in heating pipe, defective thermostat/motor valve, incorrect setting of control panel.

If none of the above errors are relevant, contact:

- During the warranty period (0-2 years), the installer from whom the unit was purchased.
- After the warranty period (2 years ->), the installer from whom the unit was purchased or the Genvex Customer Centre by calling 7353 2700.

Please have the data from the type plate ready (silver plate on the unit).

Alerts

See Optima 270 operating instructions.

ELECTRICAL DIAGRAM OPTIMA 270 - RIGHT

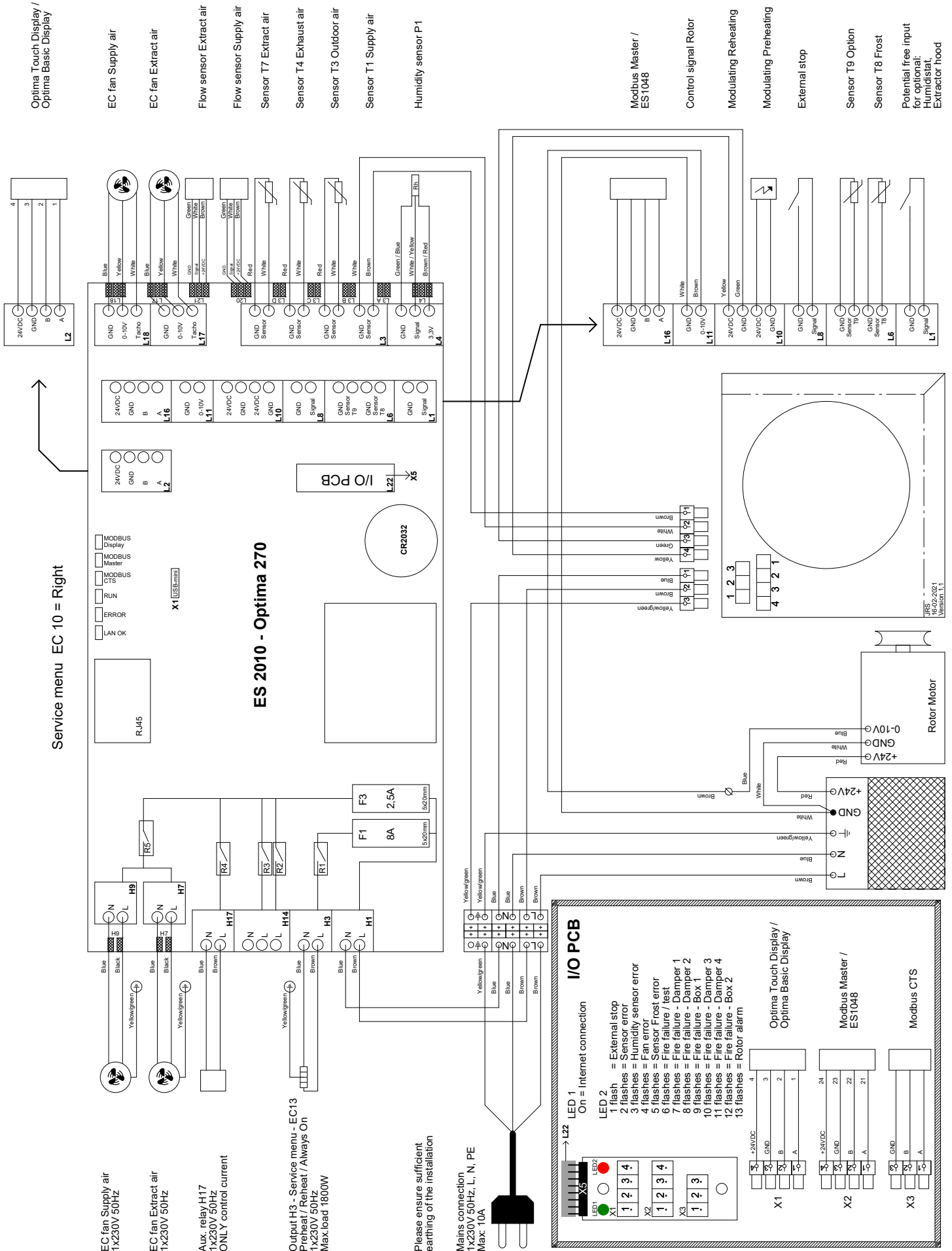

ELECTRICAL DIAGRAM OPTIMA 270 - LEFT

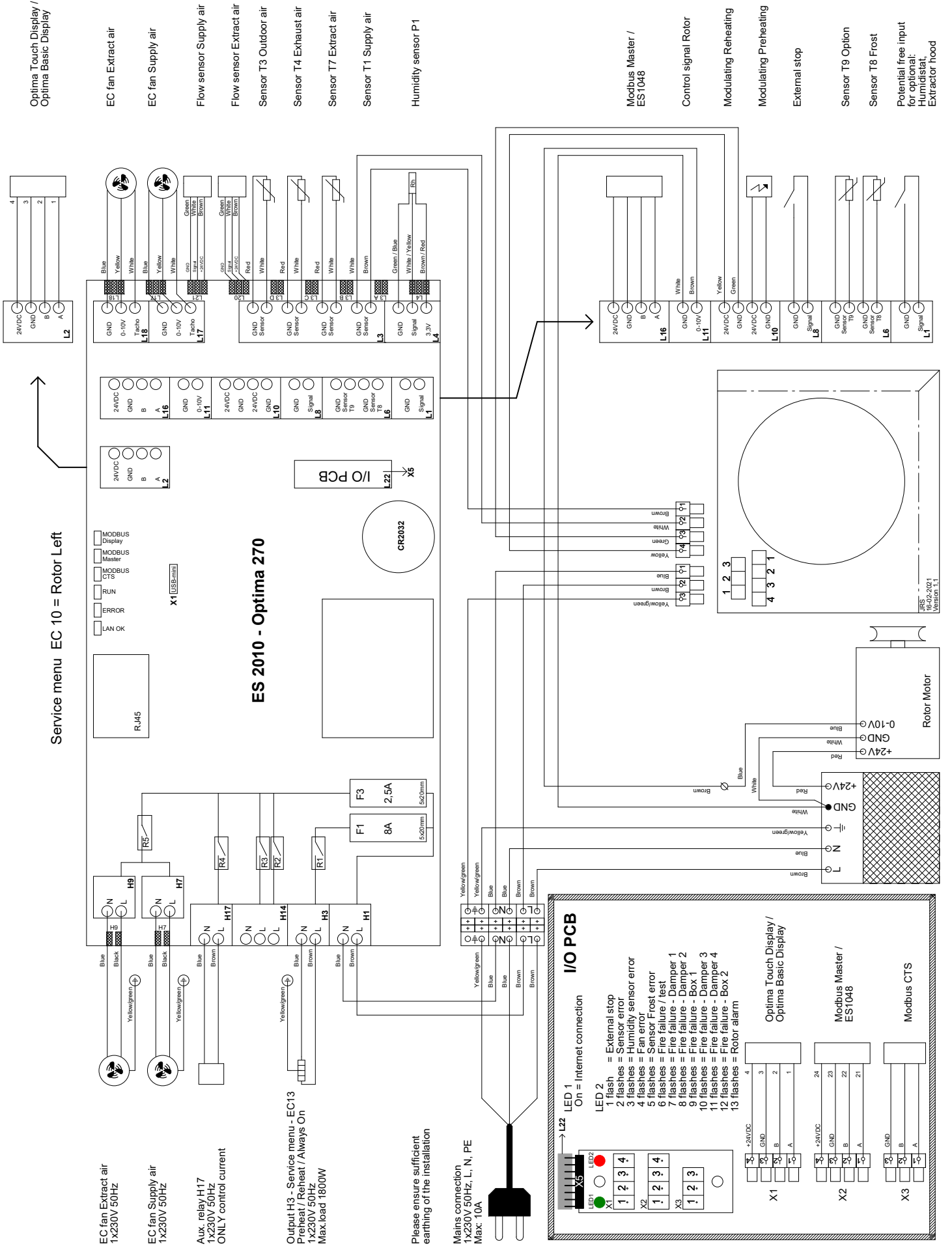

POWER CONSUMPTION

Power consumption of display, control board and rotor

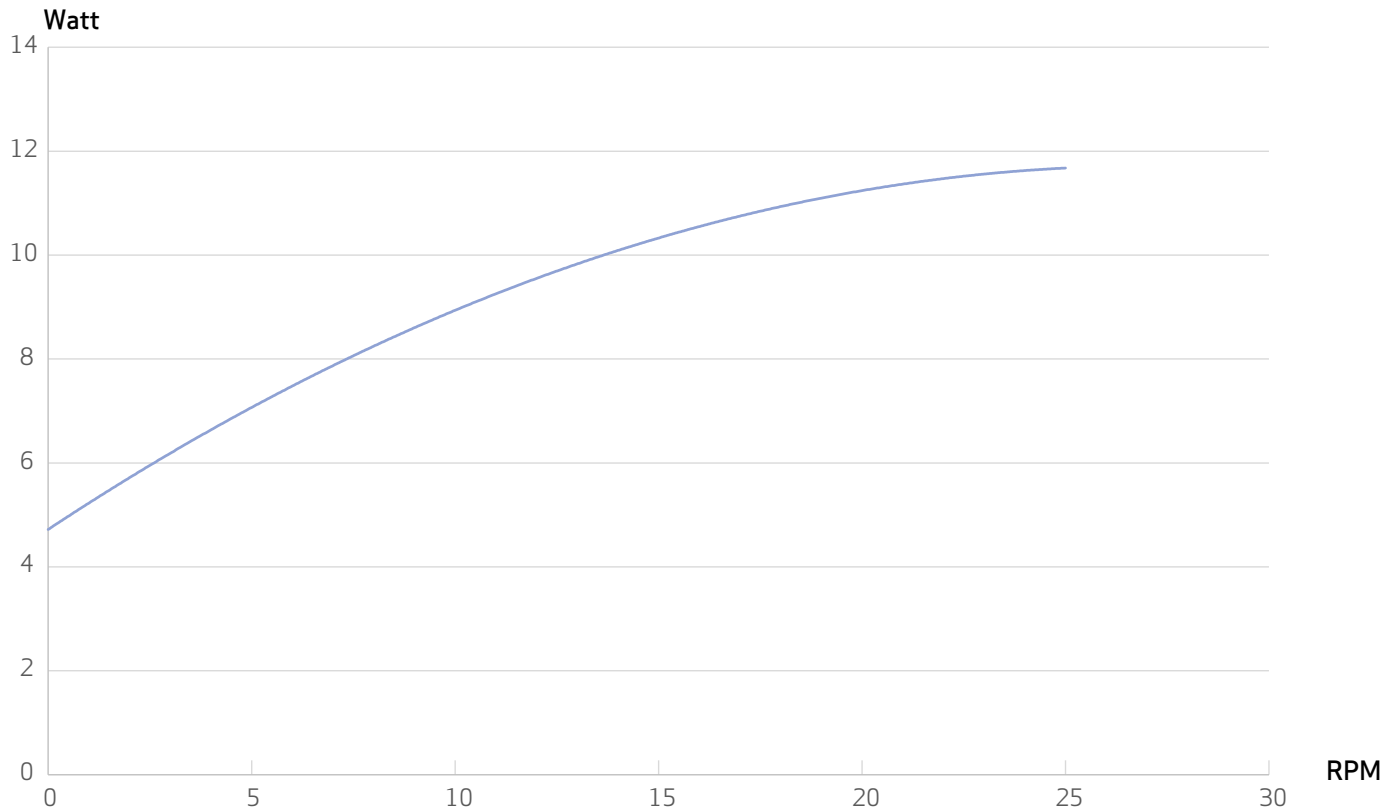

Heat and moisture recovery rotor according to 13141-7

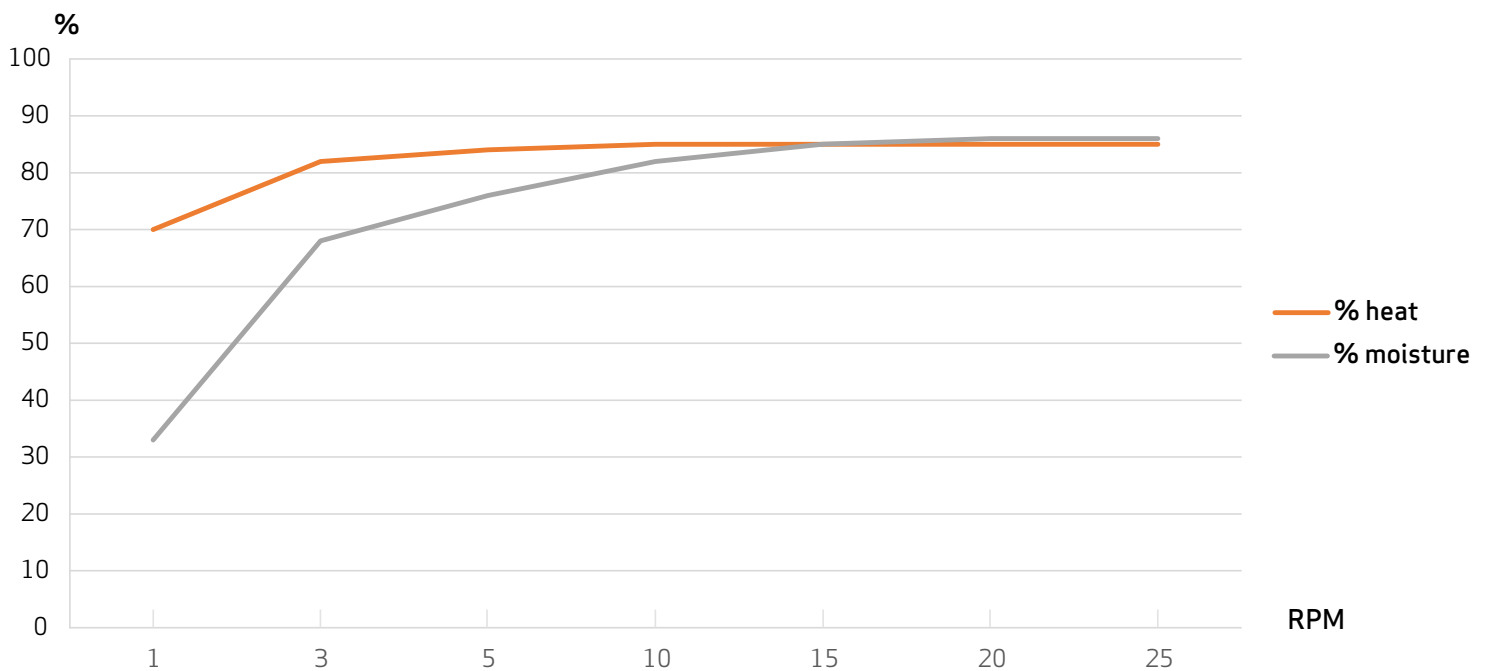

DECLARATION OF CONFORMITY

The declaration of conformity can be downloaded from www.genvex.com.

DE-COMMISSIONING INSTRUCTIONS

For further information on dismantling components with a view to disposal and recycling, see illustrations under "System maintenance"

THE AIR WE BREATHE

All
Genvex
systems are
rated with
energy label

A

The original Genvex units are assembled by skilled and experienced technicians and have a lifetime that in many cases is measured in decades. The units are approved by all applicable standards and are easy to operate and service. Last – but not least all Genvex systems are developed with focus on compact dimensions and ease of installation and can be integrated discreetly in all types of homes.

We are part of the NIBE Group – a family of companies that specialize in supplying hot water, heating and home comfort to homeowners worldwide.

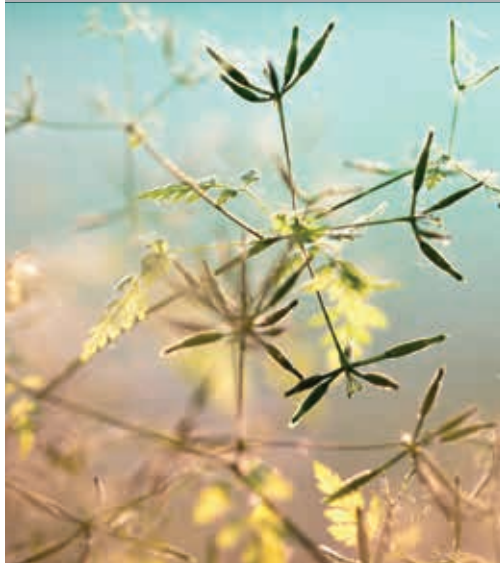

Genvex – The original Danish Ventilation System

Genvex is a genuine Danish original. We invented the ventilation system more than 40 years ago, and we are still ahead of the pack when it comes to development and production of the strongest and most durable ventilation system.

Our unit is working in thousands of homes providing fresh clean air – free of pollen, dust and harmful particles. This helps to strengthen the health of the house and to make the indoor environment healthy and comfortable for lots of families. At the same time, our system is an important element when it comes to saving energy in homes and in society as a whole – in fact you can recover up to 95% of the heat energy with a Genvex system.

Please visit www.genvex.com to see a list of our distributors

