

# INSTALLATION MANUAL



## ECO 400 XL

Mechanical ventilation with passive heat recovery

# TABLE OF CONTENTS

<b>Safety information</b> .....	<b>3</b>
<b>Functional description</b> .....	<b>4</b>
<b>Installation</b> .....	<b>5</b>
Technical drawing .....	6
Duct connection .....	7
Duct system .....	7
Condensation water drain .....	8
Insulation of ducts in cold attics .....	9
Insulation of ducts in heated rooms .....	10
Reheating supply air .....	10
Preheating outdoor air .....	11
Electrical installation .....	11
Control and calibration of the system .....	11
Optimal initial calibration of the system .....	12
System maintenance .....	12
Recommended maintenance intervals .....	14
<b>Spare parts</b> .....	<b>15</b>
<b>Trouble shooting</b> .....	<b>16</b>
Safety thermostat in electric heating surface (accessory) .....	16
System not running .....	16
No supply air .....	16
No exhaust air .....	16
Cold supply air .....	16
Alerts .....	16
<b>Electrical diagram - Optima 270</b> .....	<b>17</b>
<b>Declaration of conformity</b> .....	<b>18</b>

# SAFETY INFORMATION

This manual also describes installation and service work to be performed by a professional.

This appliance can be operated by children aged 8 and over, by persons with reduced physical, sensory and mental abilities, and by persons with a lack of experience and knowledge, provided they are supervised or have received guidance on using the appliance in a safe way and understand the dangers involved. Children must not play with the appliance. Cleaning and user maintenance must not be performed by children without supervision.

Subject to design changes.

## **Labelling**

The UKCA/CE mark represents Genvex's assurance that the product complies with all regulations for the product in accordance with relevant UK and EU directives. The UKCA/CE mark is mandatory for most products sold in the EU and the UK, irrespective of where they are made.

# FUNCTIONAL DESCRIPTION

ECO 400 XL is a horizontally mounted ventilation system for comfort ventilation in homes and small businesses.

The system is fitted with a high efficiency counter flow heat exchanger, which recovers heat from exhaust air in the property and preheats the fresh supply air.

ECO 400 XL can be configured as both right and left hand facing depending on installation conditions.

An integrated modulating electric preheater can be selected for the system, which ensures that balanced air volumes can be maintained – even during periods of very cold outdoor temperatures.

You can also choose an integrated water level switch, which ensures the system stops and an alarm is shown on the display if problems with the condensate drain occur (e.g., clogged drain).

ECO 400 XL is designed for installation outside the building envelope and has low heat loss due to its high heat-insulating capacity. The system must be installed so that it is protected from wind and weather.

Where installation conditions permit, the ECO400 XL unit can also be installed indoors.

# INSTALLATION

## IMPORTANT:

Follow these instructions when installing the ECO 400 XL:

- 1) The system must be installed to allow the condensation water to drain freely.
- 2) An airtight drain trap must be installed in a frost-free location to compensate for fan pressure.
- 3) The drain trap must be a minimum of 50 mm in height.
- 4) Ensure the fall in the drain extends all the way to the drain outlet.
- 5) Pour 1 litre of water into the condensate tray of the unit to check that it drains correctly. Make sure the drain trap is filled with water every year before beginning to use the unit.
- 6) If the drain trap is installed in an area where temperatures can drop below 0°C, then the drain trap must be protected against freezing by a thermostat and an electric heating element that turns on when the temperature drops below +2°C.
- 7) The airflow volume for the supply air and exhaust air must be adjusted before using the unit. It is important to maintain an air balance inside the house.
- 8) We recommend closing the ceiling vents, etc., until the system has been started up and adjusted.

KVM-Genvex A/S always recommends careful planning of the installation space for your Genvex product in relation to the location of living spaces. As this is a technical product that contains fans and/or a heat pump, in rare cases, and in combination with inappropriate installation conditions, it may cause unsatisfactory noise or vibration nuisances. As a rule, we always recommend installing the technical system so that it is not located in the immediate vicinity of a bedroom. Furthermore, when securing the Genvex system to the building structure, it is recommended attaching it to a heavy structural component such as concrete. It should also be ensured that no sound or vibrations can be transmitted through materials in contact with the technical system. If there is a risk of propagation of noise and vibrations, further installation of vibration-damping material and sound-damping of installation rooms are recommended.

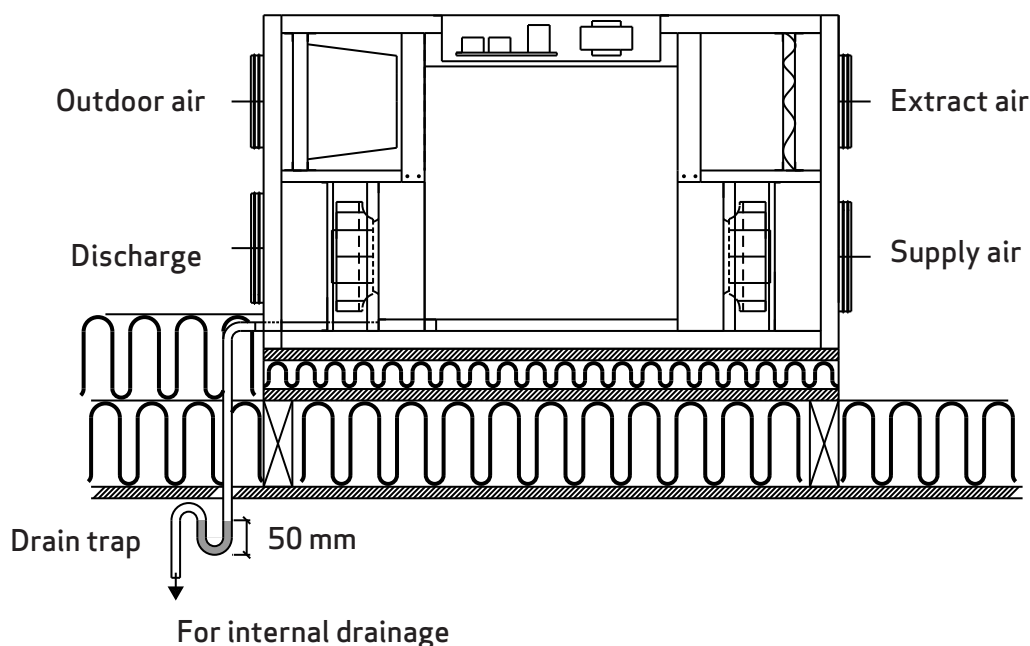

## Technical drawing in mm

1. Outdoor air
2. Discharge air
3. Extract air
4. Supply air
5. Heat exchanger
6. Supply air fan
7. Extract air fan
8. Filter outdoor air
9. Filter extract air
10. Condensate drain
11. Electrical connection

The ECO 400 XL is delivered as right-facing (as shown in the drawing below). If you want the condensate drain at the opposite end, simply remove the front cover and back panel on the unit, then install the back panel on the front and turn the unit 180°.

The unit must be placed on a surface so that vibrations from the unit are not transmitted down through the ceiling and walls. As the unit can produce up to 8 litres of condensation water per day during the winter period, the condensate drain, together with the requisite drain trap, must flow frost-free to the internal drain.

To service and maintain the unit, there must be at least 600 mm of clearance in front of the unit and a surface that can be walked on. If the unit is placed in the attic, then there must be free access from the attic hatch to the unit.

Weight: 56 kg

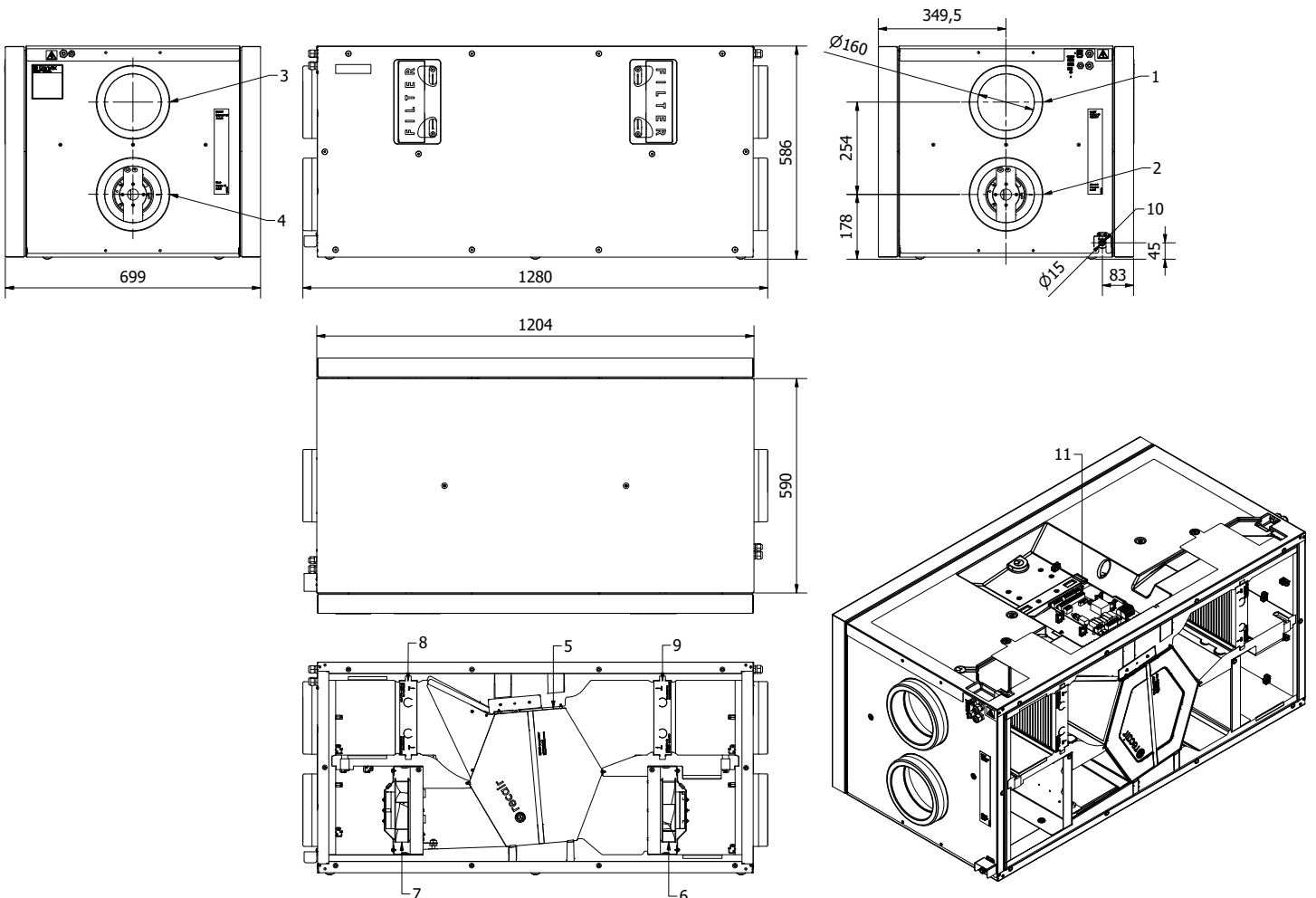

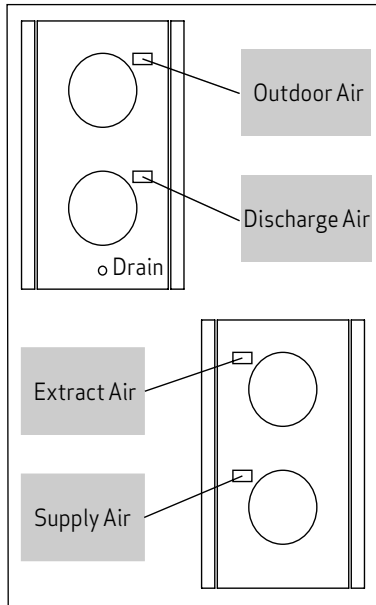

## Duct connection

A label is affixed to all duct sockets, indicating which ventilation ducts should be connected to the various sockets.

### Connect supply air

Duct system from unit to supply air in living room.

### Connect extract air

Duct system from wet rooms to the unit.

### Outdoor air connected

Duct system from outdoor air intake hood/outdoor air intake grille from outdoors or from the ground exchanger to unit.

### Discharge is connected

Duct system from unit to exhaust hood/exhaust grille to open air.

## Duct system

It is recommended that the duct system is constructed using spiral-folded pipes and fittings with rubber ring seals to achieve a tight and long-lasting duct system.

To achieve a satisfactorily low noise level from the unit, attenuators must always be fitted to the supply and exhaust air duct system between the unit and the first supply and exhaust air fittings.

Air velocities in the ducts should be dimensioned at a sufficiently low rate so that no noise is generated by the supply and extract air fittings.

When placing outdoor air and exhaust air hoods/gratings, care must be taken not to short-circuit the two airflows, thus causing return air to avoid being sucked back in.

It is recommended that gratings be placed on the north or east side of the house for optimal comfort in homes/apartments.

Minimum distance: 3 metres

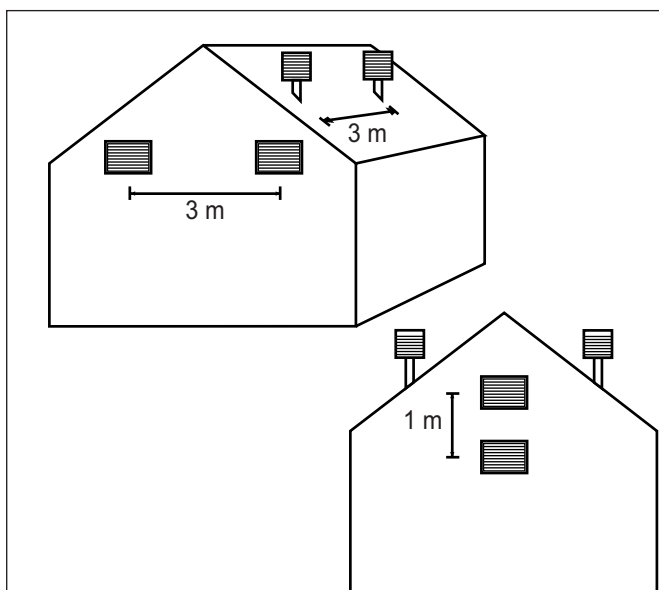



Ø15 mm condensate water connection on ECO 400 XL

## Condensate water drain

### Condensate drain

The ventilation unit produces up to 8 litres of condensation water per day. It is therefore important to mount the condensate drain correctly. An ordinary Ø15 mm hose can be connected directly to the ventilation unit.

It is important to make a loop on the hose, so that a drain trap with a minimum of 50 mm is formed.

### Water column

There must be a slope of 1% from the drain trap and the hose towards the drain. If the unit is installed in a cold environment the condensate drain must be insulated to prevent the condensation water in the pipe from freezing. However, it is recommended that the drain trap is installed in a heated area to ensure that the water inside it does not freeze. If installation problems make it impossible to protect the condensate drain against frost using insulation, then a thermostatically controlled heating wire must be installed around the condensate drain. During operation, the unit experiences internal negative pressure. Therefore, it is necessary to ensure a water column height of at least 50 mm in the drain trap under all conditions.

If the MVHR unit is installed in a cold attic, the condensation water drainpipe must be insulated so that the condensation water in the pipe does not freeze.

We also recommend installing the drain trap in a heated room below to ensure that the water in the drain trap does not freeze.

If it is not possible to protect the condensation water drainpipe against freezing by insulating it, then a thermostatically controlled heating element must be installed around the condensation water drainpipe.

When hanging on a wooden wall, a vibration damper is recommended to avoid vibration transmission.

As an alternative to the looped drain trap, a Genvex universal drain trap with hose connection can be used, product no. 063289 (see the photo to the left).



Genvex universal drain trap



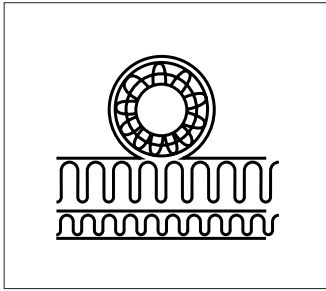

Insulation of ducts, alt. A

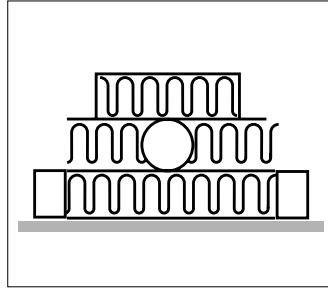

Insulation of ducts, alt. B

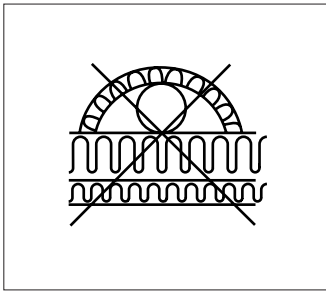

Incorrect insulation of ducts

## Insulation of ducts in cold attics

To utilise the full heat recovery capacity of the units, the ducts must be properly insulated.

Genvex recommends the following:

### Supply air and extract air ducts

To minimise heat loss from the duct system in cold attics, supply and extract air ducts should be insulated with a minimum of 100 mm insulation. If insulation form alternative (A) is used, it is recommended that the insulation is made of 2 x 50 mm lamella mats with paper or aluminum foil on the outside, and with staggered joints between the 2 insulation layers. If the ducts are laid out on the truss frame, alternative B can be used. Insulation must always be tightly wrapped around the ducts.

### Outdoor air and discharge air ducts in cold rooms

It is recommended that fresh air and discharge air ducts are insulated with a minimum of 50 mm insulation finished with aluminium foil. Insulate the outdoor air duct to prevent hot air in the attic from heating the outside air during summer.

Be careful to seal where the exhaust duct passes through the roof or out through the gable to avoid condensation damage.

Contact your local supplier for guidance on national insulation guidelines.

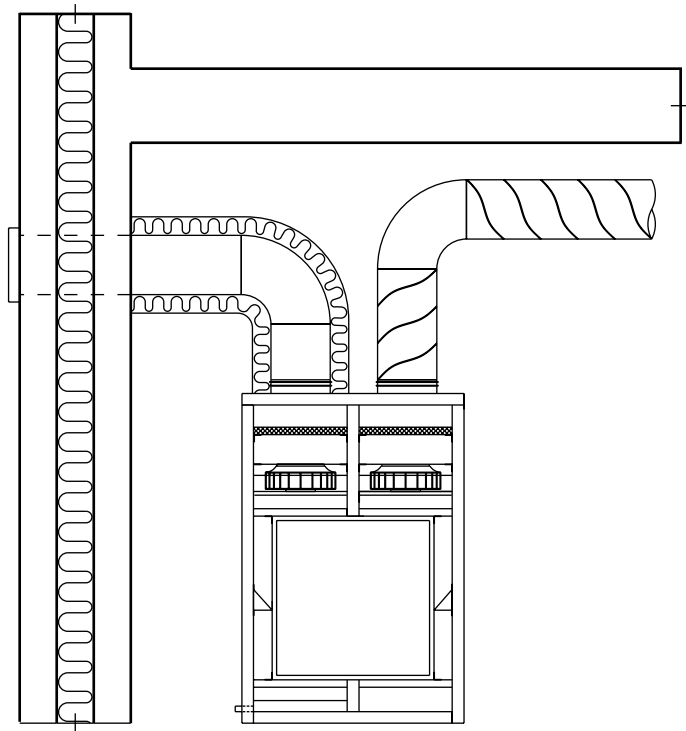

## Insulation of ducts in heated rooms

Genvex recommends the following:

### Supply air and extract air ducts

In a warm attic, the supply air and extract air ducts must have 50 mm of insulation finished with aluminium foil. Supply air and exhaust air ducts routed through heated rooms in the home do not need to be insulated unless cooling, a bypass or a geothermal heat exchanger are used. In this case, the supply air duct must be insulated. In this case, the supply air duct must be insulated.

### Outdoor air and discharge air ducts

In warm attics and heated rooms in the home, outdoor air and discharge ducts must have a minimum of 50 mm of insulation. Furthermore, the outside of the insulation must be covered with plastic or aluminium foil to prevent condensation water in the insulation.

Contact your local supplier for guidance on national insulation guidelines.

When using a geothermal heat exchanger, it is recommended to add 100 mm of insulation to the outdoor air duct.

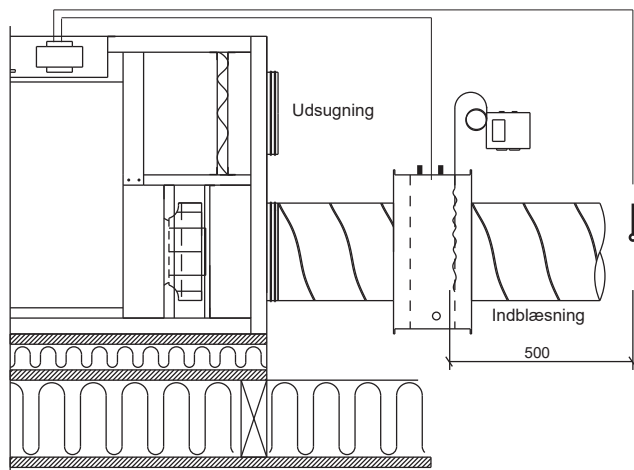

With water heating surface

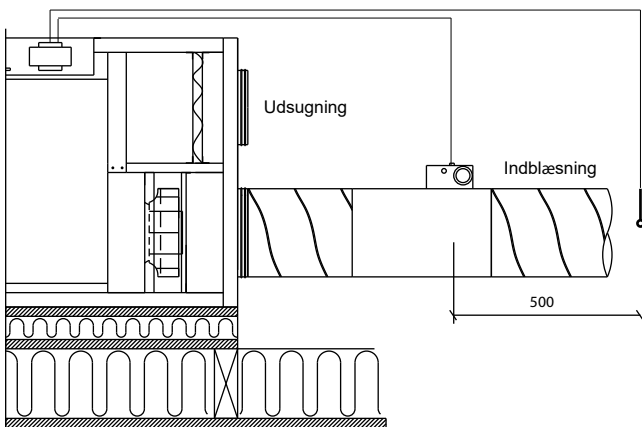

With electric heating surface

## Reheating supply air

The counter flow heat exchanger cannot fully recover all heat from exhaust air to supply air, so during winter the supply air will be approximately 1-4°C lower than the ambient temperature in the property. If the system is intended for use in heating, then a water or electric heating surface can be installed to heat the supply air to room temperature.

### Water heating surface

To protect the water heating surface against frost damage, a water frost sensor must be installed on the system and the water heating surface must be insulated. The water frost sensor is installed on the back of the slats of the water post-heating surface. The sensor for controlling the motor valve is installed in the supply air duct approximately 500 mm after the water heating surface so that it is not affected by radiant heat from the heater. The water connection to the water heating surface must be carried out by an authorised plumber.

### Electric heating surface

The sensor for controlling the electric heating surface is installed in the supply air duct approximately 500 mm after the electric heating surface so that it is not affected by radiant heat from the heating unit.

## Preheating outdoor air

### Electric preheater

At outdoor temperatures below 0°C and if software deicing cannot be used, we recommend installing an electric preheater to prevent ice from accumulating in the counter flow heat exchanger.

It may be beneficial to use a factory-fitted integrated electric preheating surface (accessory).

## Electrical installation

Connection to the mains must be carried out by an authorised electrician. See the accompanying wiring diagram.

ECO 400 XL is supplied with 230-volt power supply cable with Type F (Schuko) plug. The side of the unit has points for connecting the Internet, display, BMS connection and Genvex accessories.



### Important!

For functional and safety reasons, the unit must be connected to a grounded socket suited to the plug.

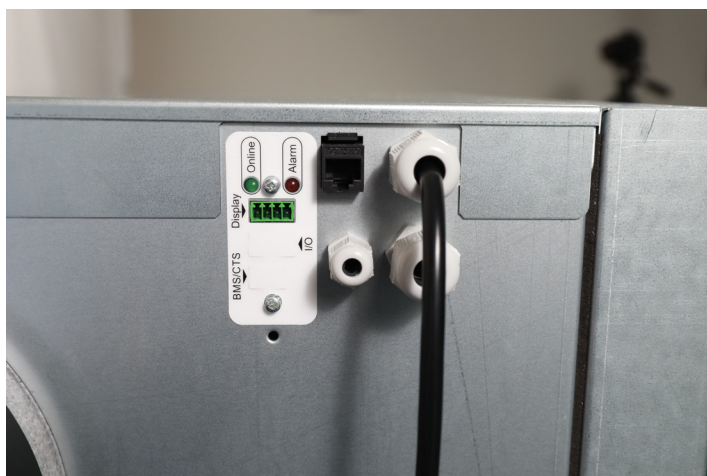

Connections for the Internet, display, CTS and accessories on ECO 400 XL

## Control and calibration of the system

To achieve optimal system operation, it must be calibrated using air measuring equipment.

If the system is to be used before it is adjusted, then the following can be done before commissioning the system:

1. Check that the ECO 400 XL is correctly installed and that all ducts are properly insulated.
2. Check that the doors can be opened to allow service and maintenance to be performed on the unit.
3. Check that the filters are clean (may be dirty after installation).
4. Check that the condensate drain is correctly fitted with a drain trap and is protected from frost. Pour 1 litre of water into the condensation water tray and ensure that it drains freely through the condensate drainpipe.
5. Set all supply air valves so that the valve plugged into the unit opens 3 turns from the closed position, while the outermost valve opens 8 turns from the closed position. The intermediate ones are opened between 4-7 depending on how close they are to the unit.

Set all exhaust air valves so that the exhaust air valve in the kitchen opens 8 turns, the exhaust air valve in the bathroom/toilet opens 7 turns and the extraction valve in the utility room opens 6 turns from the closed position.

6. If a heating surface is fitted to the system, the supply air temperature is set to 0-3°C below the room temperature in the property.

The system can now be put into operation and can operate until the system is calibrated using air technique measuring equipment.

## Optimal initial calibration of the system

Genvex recommends that the ventilation unit should be calibrated by an authorised Genvex dealer before it is put into operation.

Before starting the initial calibration, check that the 6 points in the section “Control and calibration of the system” have been performed. Then start the unit:

Set the initial basic ventilation value, which is speed 2. To reduce energy consumption as much as possible, first adjust the main air volumes to the desired levels by adjusting the speed of the fans via the control panel.

Then adjust the supply air and extract air valves with air measuring equipment (during the initial calibration of the valves, remember to lock them and turn the baffle plate in the supply air valves so that the air blows in the right direction).

Then check the main air volumes again and fine-tune them using the fresh air and exhaust air valves (remember to lock the position of the valves after initial calibration).

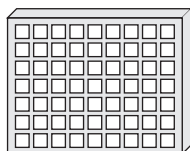

G4/Coarse = Standard filter (coarse filter class G4)

F7/ePM1 = Pollen filter (fine filter class F7)

## System maintenance

REMEMBER TO SWITCH OFF THE POWER BEFORE OPENING THE UNIT.

### Filters

When the filter timer reaches the set value for a filter change, this will appear in the text of the Optima Touch display or in the Genvex app or be indicated with a yellow flashing light in Optima Basic. This means that the filters must be replaced/cleaned.

The system is stopped by pulling the plug out of the socket or via the switch on the electrical panel. The front doors are opened and the filters removed. Once the filters have been cleaned/replaced, the front doors are closed and the filter alarm can now be reset via the display or app. The system then returns to normal operation.

If you want to replace the filters with a different time interval, this can be done via the user menu.



Do not vacuum or clean the filter using pressurised air. This will damage the filter!

## Filter replacement

1. Open the filter plug.



2. Place your fingers in the recesses in the filter frame.



3. Carefully pull out the filter and replace with a new filter.



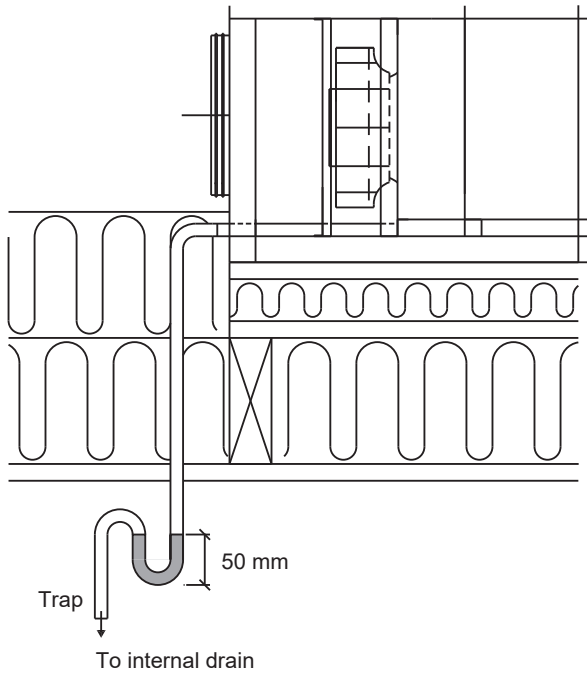

### Condensate drain

During the filter change before autumn, the condensate drain should be checked to ensure it is not clogged with dirt and to ensure there is water in the drain trap.

Pour 1 litre of water into the condensation water tray and ensure that it drains away freely. If the condensation water drain does not function properly, then this may result in water damage to your home.

### Counter flow heat exchanger

Inspect the counter flow heat exchanger annually. If it is dirty, remove the unit and wash it in lukewarm water with soap and rinse it in the bathroom with a shower head.

### Fans

Remember to turn off the power.

Annually check the fan wheels for dirt.

Remove the front cover of the unit. Clean the fans with a brush or bottle cleaning brush. Note: please do not remove the balancing weights on the fan wheels, as this will lead to an imbalance in the unit with a higher noise level and cause more wear on the fans.

### Supply air and extract air valves

Clean the vents by wiping them with a dry cloth. Ensure the vent does not rotate causing the airflow to change.

### Service

If you are unable to maintain your system, you can sign a service agreement with the Genvex service department. If the system is faulty, please contact the Genvex service department.

## Recommended maintenance intervals

Component	Maintenance	Interval
Filter	Replaced at set intervals so the unit is fully efficient.	3-6 months
Fans	Fans must be cleaned with a soft brush to ensure operational safety and efficiency.	12 months
Counter flow heat exchanger	Clean with water	12 months
Gaskets	Give the gaskets on the system a general check and ensure they are intact	12 months
Supply air and extract air valves	Check for dirt inside the supply air and exhaust air valves. Clean as needed. Check that the valves have the desired setting in relation to air volumes.	12 months
Air intake	Check for dirt and grime inside the air intake and discharge air vents and clean as needed	12 months
Ventilation ducts	Check the cleanliness of ducts and clean as needed.	10 years

# SPARE PARTS

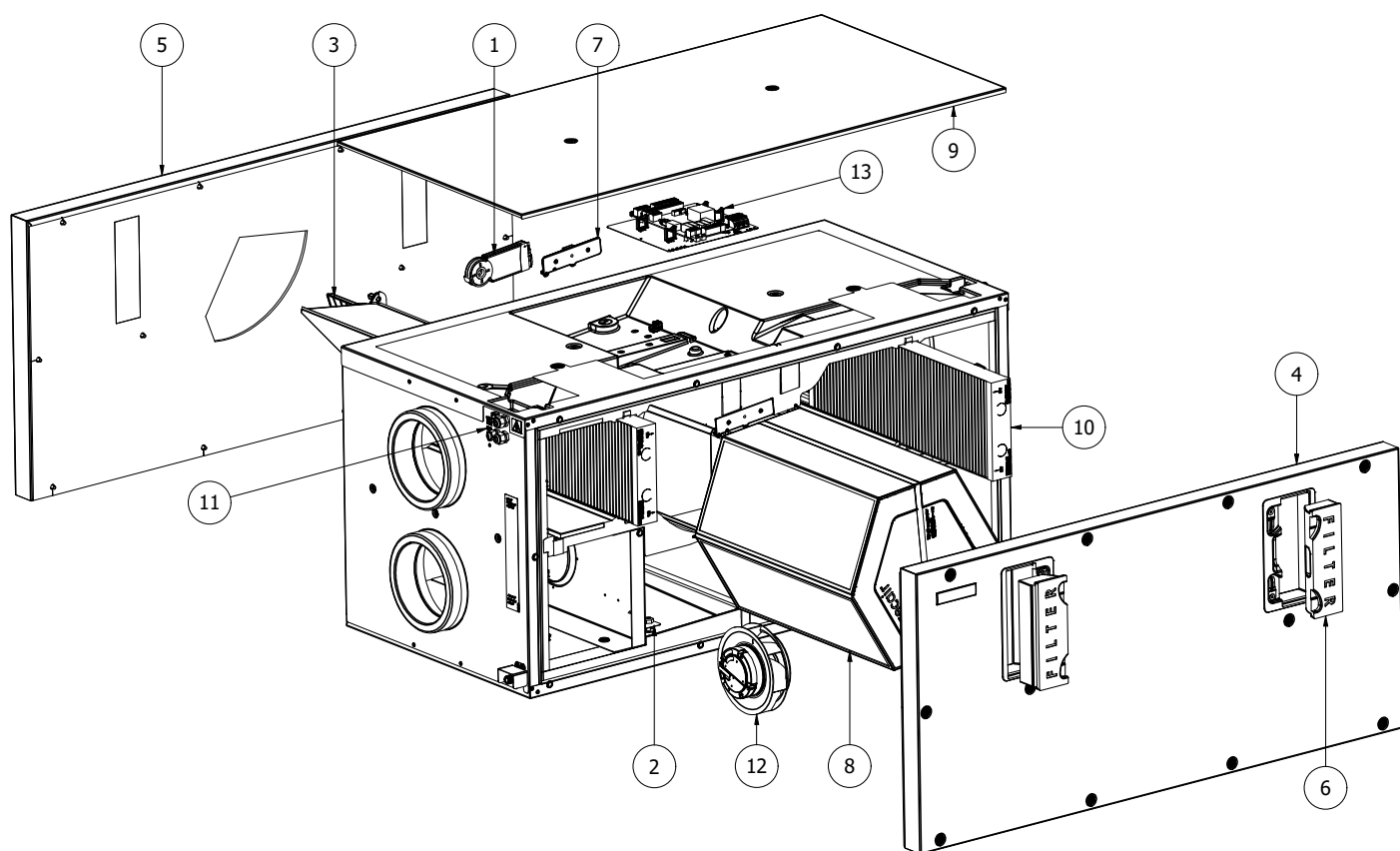

Pos.	Varenr.	Beskrivelse
1	060538	Belimo bypass motor
2	069362	Levelswitch (accessory)
3	069505	Bypass assembly
4	069506	Frontlid assembly
5	069507	Backlid assembly
6	069540	Filterplug
7	069548	Plastic bracket for heatexchanger
8	069591	Heatexchanger RS 160 x 500
9	069593	Metallid top
10	069597	Filter G4 / Coarse
10	069598	Filter F7 / ePM1
11	069876	IO PCB
12	070055	Fan
13	073077	PCB assembly OPT270

# TROUBLESHOOTING

## Safety thermostat in electric heating surface (accessory)

If a fault occurs in the built-in electric heating surface, the safety thermostat will switch off the unit. The electric heating surface is controlled by a fire thermostat, which automatically cuts off the power if the temperature exceeds 35°C. When the temperature drops, the heating surface switches on again automatically. For extra safety, a thermal fuse is built in, which switches off if the temperature exceeds 45°C.

The thermostat must be manually reconnected.

**Remember to disconnect the power from the system!**



Built-in electric heating surface in ECO 400 XL

## System not running

- Fuse in electric panel has blown, no voltage in the system.
- One of the fuses in the system's control board has blown.
- Loose cable, no voltage to the unit.
- Incorrectly set weekly program.
- Filter timer has switched off the system.

## No supply air

- Defective supply air fan.
- Clogged supply air filter.
- Outdoor air grille clogged with dirt and leaves during autumn or snow and ice during winter.
- Fuse on control board has blown.
- Unit is defrosting (supply air fan runs at reduced speed)
- Incorrect setting of Optima controls

## No exhaust air

- Defective exhaust fan.
- Clogged exhaust filter.
- Fuse on control board has blown.

## Cold supply air

### *Fault*

- Heat exchanger is clogged.
- The exhaust fan is defective.
- The exhaust air filter is clogged.
- Disconnect the electric preheating surface from the overheating thermostat (only systems with an electric preheating surface installed).
- Air in heating pipe, defective thermostat/motor valve, incorrect setting of control panel.

### *If none of the above errors are relevant, contact:*

- During the warranty period (0-2 years), the installer from whom the unit was purchased.
- After the warranty period (2 years ->), the installer from whom the unit was purchased or the Genvex Customer Centre by calling 7353 2700.

Please have the data from the name plate ready.

## Alerts

See Optima 270 operating instructions.



# ELECTRICAL DIAGRAM - OPTIMA 270

Service menu EC 10 = Right

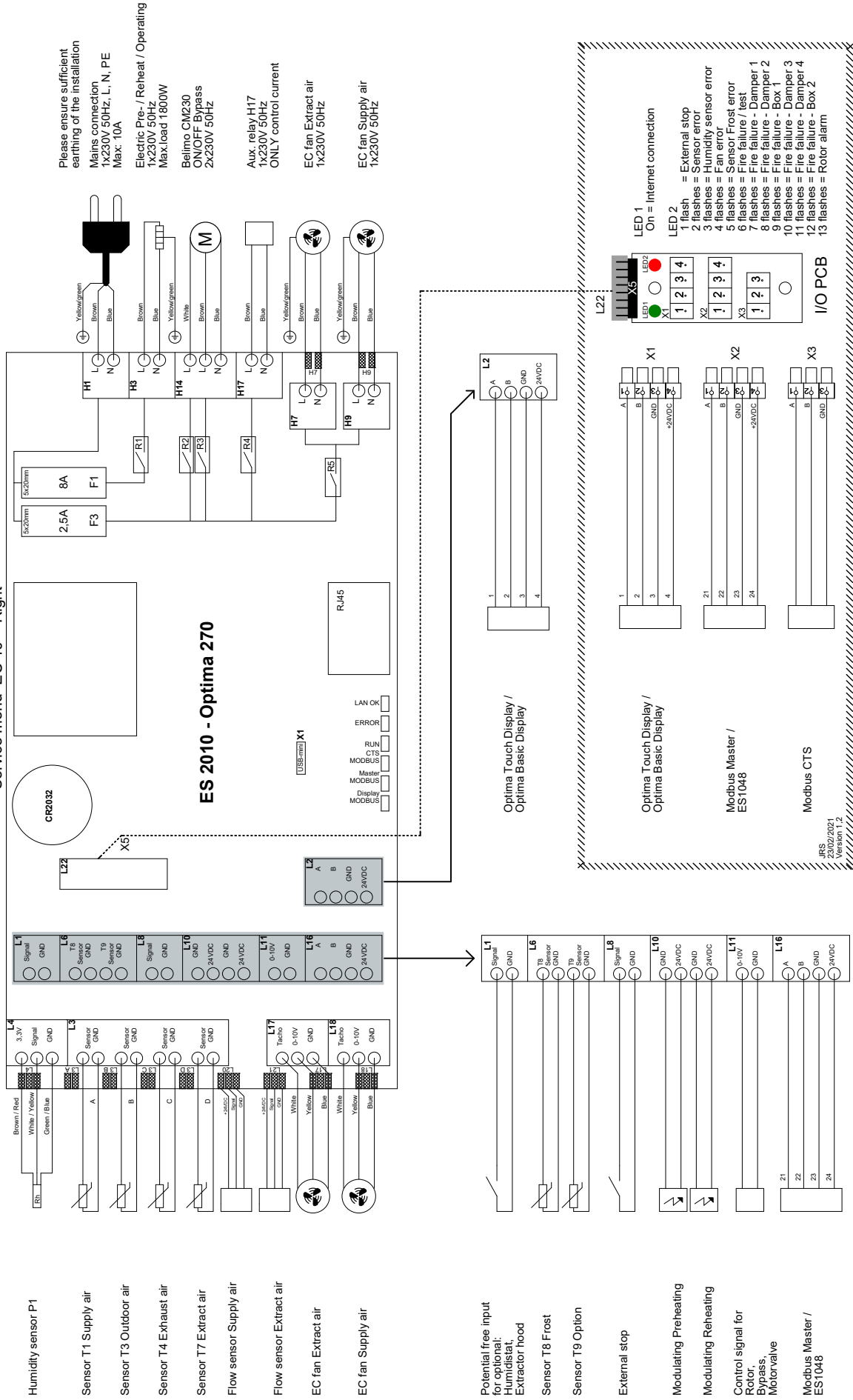

Please ensure sufficient earthing of the installation  
Mains connection  
1x230V/50Hz, L, N, PE  
Max: 10A

Electric Pre- / Reheat / Operating  
1x230V/50Hz  
Max. load 1800W

Belimo CM230  
ON/OFF Bypass  
2x230V/50Hz

Aux. relay H17  
1x230V/50Hz  
ONLY control current

EC fan Extract air  
1x230V/50Hz

EC fan Supply air  
1x230V/50Hz

JRS 09/09/01  
Version 1.2

# DECLARATION OF CONFORMITY

The declaration of conformity can be found on our website: [www.genvex.com](http://www.genvex.com)

# THE AIR WE BREATHE

All  
Genvex  
systems are  
rated with  
energy label  
**A**

The original Genvex units are assembled by skilled and experienced technicians and have a lifetime that in many cases is measured in decades. The units are approved by all applicable standards and are easy to operate and service. Last – but not least all Genvex systems are developed with focus on compact dimensions and ease of installation and can be integrated discreetly in all types of homes.

We are part of the NIBE Group – a family of companies that specialize in supplying hot water, heating and home comfort to homeowners worldwide.



## Genvex – The original Danish Ventilation System

Genvex is a genuine Danish original. We invented the ventilation system more than 40 years ago, and we are still ahead of the pack when it comes to development and production of the strongest and most durable ventilation system.

Our unit is working in thousands of homes providing fresh clean air – free of pollen, dust and harmful particles. This helps to strengthen the health of the house and to make the indoor environment healthy and comfortable for lots of families. At the same time, our system is an important element when it comes to saving energy in homes and in society as a whole – in fact you can recover up to 95% of the heat energy with a Genvex system.

Please visit [www.genvex.com](http://www.genvex.com) to see a list of our distributors

