

# INSTALLATION AND OPERATION INSTRUCTIONS

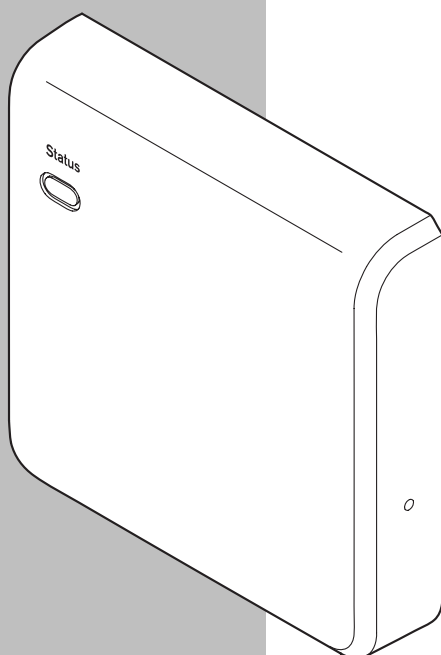

## A+ INPUT/OUTPUT MODULE

# INSTALLATION

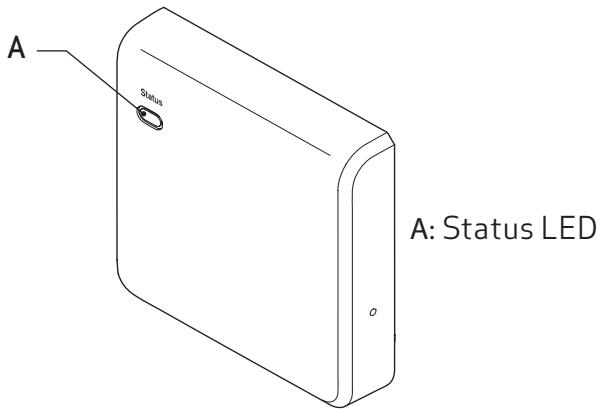

## 1. About this manual

### 1.1. About the device

The input / output module is a control device for a ventilation system. This device converts wireless control commands into an electrical control signal, and electrical status signals into wireless status commands.

### 1.2. How to use this manual

This manual is intended as a reference book by which qualified installers can install the input / output module (henceforth called “device”) and users can use the device for its intended purpose. Make sure you have read and understood the manual before you install and/or use the device.

### 1.3. Original instructions

The original instructions for this manual have been written in English. Other language versions of this manual are a translation of the original instructions.

### 1.4. Admonitions

 **WARNING**  
'Warning' identifies a hazard that could lead to personal injury, including death.

 **NOTE**  
'Note' is used to highlight additional information.







## 2. Safety

### 2.1. Directives

The device meets the following EC directives:

- EMC directive: 2004/108/EC
- Low voltage directive: 2006/95/EC
- RTTE directive: 1999/5/EC
- RoHS directive: 2002/95/EC
- WEEE directive: 2002/96/EC

### 2.2. Signs on the unit

-  Caution. Check the instructions for use for important cautionary.
-  Danger: risk of electric shock.
-  IEC 61140 protection Class II (double insulated)
-  CE marking of conformity
-  Use of the device may not be legal in every member state.
-  Dispose according to European Community Directive 2002/96/EC (WEEE).

### 2.3. General safety instructions

This product was designed and manufactured to ensure maximum safety during installation, operation and service. Always read these safety instructions before installing, maintaining or servicing the product, and strictly comply with these instructions. Parts of the device carry mains power, which is a potential lethal voltage. Disconnect power at supply line, circuit breaker or fuse before installing, servicing or removing the device.

The device is designed for indoor use only. Do not expose the device to rain or moisture, to avoid short circuit. Short circuit may cause fire or electric shock hazard. Operate the device between 0°C and 40°C. For cleaning of the device use a soft damp cloth only. Never use any abrasive or chemical cleaner.

## 3. Description

### 3.1. Intended use

*The device is designed for following purposes:*

1. To set the speed level of ventilation through the fan speed, based on user input, measured humidity level or measured CO<sub>2</sub> level.
2. To set parameters for the ventilation control.  
Every other or further use is not in conformance with the intended use.

### 3.2. Working principle

The device outputs a 0-10V DC signal to control a ventilation system.

To define how the ventilation system must be controlled, the device receives input from one or more control device(s) via wireless communications. Various control devices are available: push button controls, humidity sensors and CO<sub>2</sub> sensors. The device sends status information back to all connected control devices.

#### 3.2.1. Ventilation speeds and modes

The ventilation system runs in one of the following modes. In each of these modes, the control device sets the ventilation system to a configured level of ventilation.

- Away mode: Low fan speed (default: 20%)
- Home mode: Medium fan speed (default: 50%)
- Timer mode: High fan speed (default: 80%), for a restricted duration.
- Auto mode: Between Low fan speed and High fan speed, based on measured values.
- Party mode: High fan speed (default 100%)

The control device drives the fan based on the highest of values sent by the bound wireless sensor(s). You can use the bound wireless sensor(s) to modify the configured fan speeds.

### 3.2.2. Inputs

The device has 2 digital inputs to receive information from the ventilation system:

The device shows an indication for the fan error on the LED. See 3.3.

### 3.3. Visual signals

Startup	LED	
Power up	Orange	Continuous
Status		
Status OK	Green	Continuous
Communication error		1flash
Filter(s) to be replaced	Red	2flashes
Fan error		3flashes
Configuration		
Binding	Red/green	

## 4. Operation

Use one of the bound wireless devices to control the device. You can set the ventilation mode, change the configuration parameters and read the system status.

## 5. Installation

### 5.1. Preparation

**⚠ DANGER**  
Disconnect power at supply line, circuit breaker or fuse before installing the device.

**i NOTE**  
Do not place the device in a metal casing.

1. Press the clip and pull the top section from the bottom section.

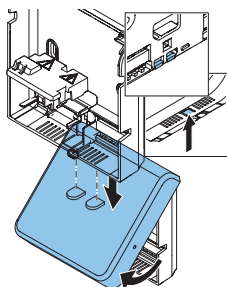

2. Open the safety cover. Use a small flat-tip screw driver to loosen the clip.

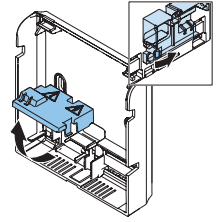

3. When you do not place the device on a flush mounted wall box:
  1. Prepare the wall, if needed. Use the mounting plate as a template.
  2. Remove the break-out plastic from the cable entrances of the housing.

### 5.2. Installation procedure

**⚠ DANGER**  
Make sure that the power supply is disabled.

1. Lead the power and IO cables through the back hole (A) or cable entrances (B).

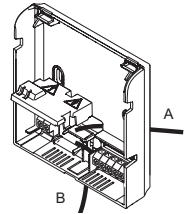

2. Place the bottom section of the device.
3. Fasten the bottom section using the screws.

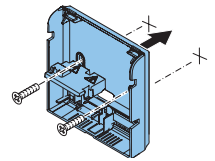

4. Connect the power cable in the screw terminals

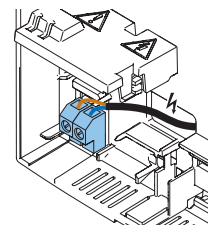

5. Connect the 0-10Vdc output cable in the screw terminals (OUT & GND).

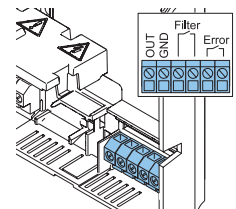

6. Connect the input cables ("Replace filter" & "Error") in the screw terminals.

7. Place the top section of the device onto the bottom section.
  - a. Place the clips.
  - b. Close and press until it clicks.

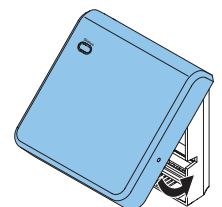

### 5.3. Commissioning

1. Enable the 230V power supply.  
The LED is orange for 3 seconds.  
After 3 seconds the LED shows the binding mode.  
The ventilation starts at 100%. After a short time, the ventilation goes to the active ventilation mode. The mode of ventilation depends on the last used mode before switching off. Default is 50%.
2. Within 5 minutes, bind all wireless controls to the device. See the manual of the used device for specific instructions.  
After 5 minutes, the LED shows the device status.

**i NOTE**  
You can bind no more than 20 devices.

### 6. Fault finding

Problem	Possible cause	How to solve
Fan does not run	The device is configured at 0% in Away .mode	Make sure that the device is status: in .auto mode /settings
	Connection(s) broken	.Check wiring
	Configuration is .invalid	Make sure that medium level between .high and low values
Control is not possible from a control device	The control device is .not bound	Restart the device, and bind the control .device again

### 7. Technical data

#### 7.1. Dimensions

Overall dimensions (h x w x d): 100 x 102 x 28 mm  
Weight: ± 125g

#### 7.2. Ambient conditions

Operating Temperature Range: 0 to 40 °C  
Shipping & Storage Temperature Range: -20 to 55°C  
Relative Humidity: 0 - 90%, non-condensing  
Ingress protection (IEC60529): IP30

#### 7.3. Electrical specification

Mains Power Source: 230VAC ± 10%, 50Hz.  
Maximum power consumption: 4VA  
Wire diameter: 0.25 to 2.5 mm<sup>2</sup>

#### 7.4. Wireless connection specifications

Communication frequency: 868.3 MHz  
Output power: at least 0 dBm.  
• Multipoint communication, max 20 devices  
• You are not allowed to use the device outside of Europe.

#### 7.5. Wired connection specifications

Output signal: 0-10V  
Input signals: Normally Open