

Combi Flex



- Supplies fresh air and hot water for the whole family
- Optional top or side connections
- Demand control via built-in humidity sensor



Combi Flex is a ventilation heat pump consisting of a ventilation section containing a high-efficiency counterflow heat exchanger with a heat recovery factor of up to 95%, a 185 litre water heater with a built-in heating coil for connection to solar panels/central heating, a combination heat pump for heating of supply air and domestic hot water, and energy-efficient supply and exhaust air fans with backward curved blades and EC motors. As standard, the system comes with a G4/Coarse supply air filter and G4/Coarse extract air filter, as well as an innovative Optima 312 controller. (Please note that control panel is sold separately.)

Combi Flex is used as a ventilation heat pump in homes where a high heat recovery rate and low energy consumption are prioritised, while the residual energy in the exhaust air is used to heat the supply air or domestic hot water.

The energy is first recovered by the counterflow heat exchanger and any remaining energy is then recovered by the heat pump.

Combi Flex can deliver a maximum airflow of approx. 350 m³/h.

Dimensions

Dimensions in mm

- | | | |
|----------------------------------|--|--------------------------------|
| 1. Discharge air | 10. High pressure switch with manual reset | 18. Extract air filter |
| 2. Supply air | 11. Cold water inlet 3/4" RG | 19. Supply air filter |
| 3. Electrical connection | 12. Hot water inlet 3/4" RG | 20. Supply air fan |
| 4. Condensate tray | 13. Connection to heating coil 3/4" RG | 21. Exhaust fan |
| 5. Compressor | 14. Connection to heating coil 3/4" RG | 22. Counterflow heat exchanger |
| 6. 185-litre tank | 15. Hot water circulation | 23. Evaporator |
| 7. 5/4" anode | 16. Outdoor air | 24. Condenser (supply air) |
| 8. 1 kW electric heating element | 17. Extract air | 25. Bypass |
| 9. Condenser coil | | 26. Bypass motor |

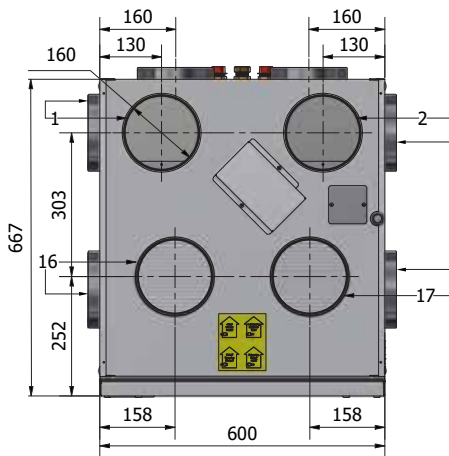
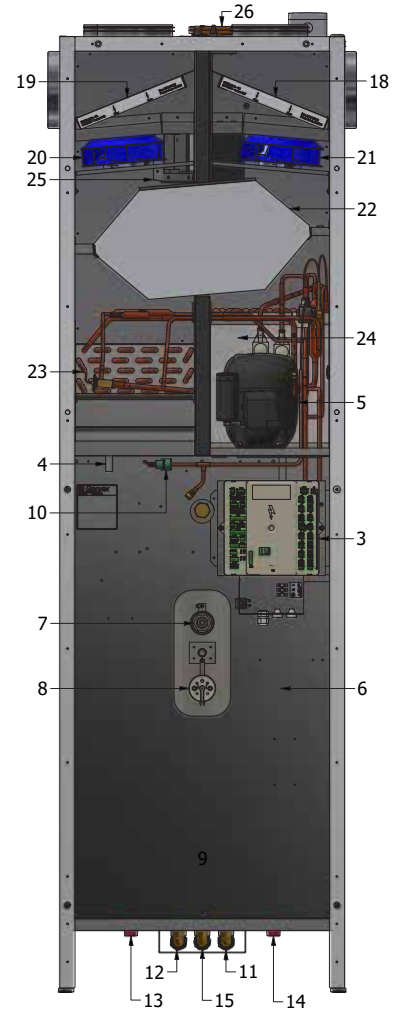
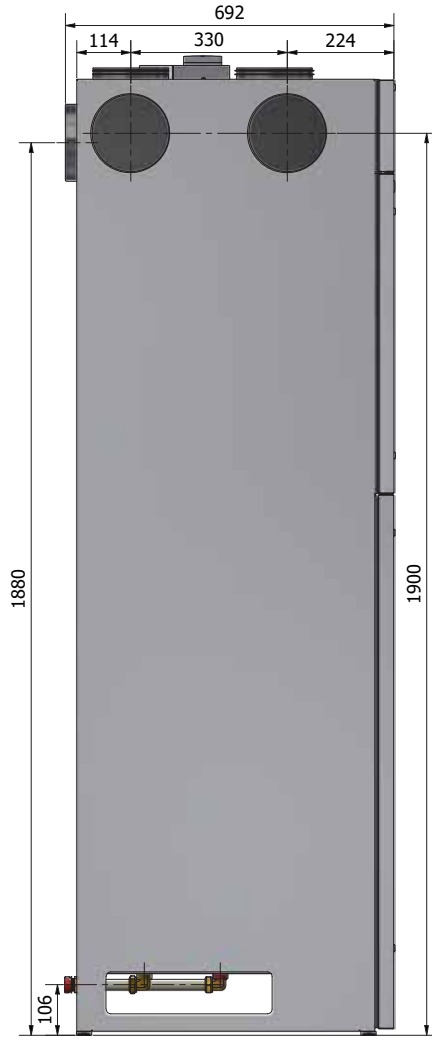
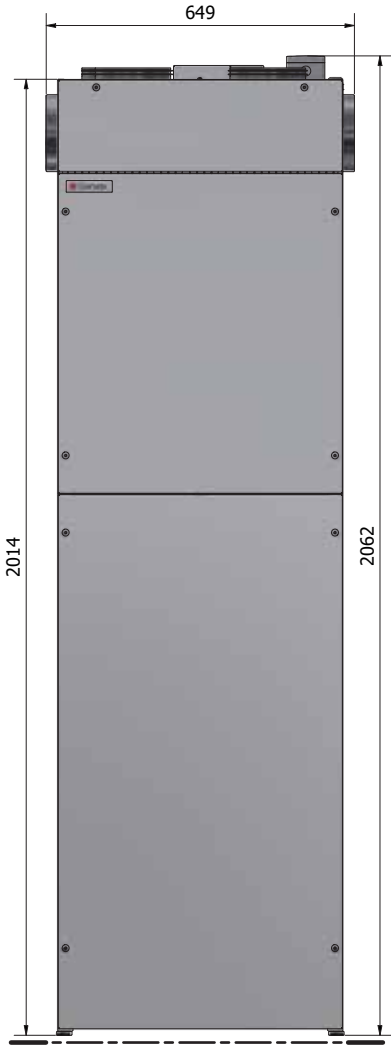

System seen from above

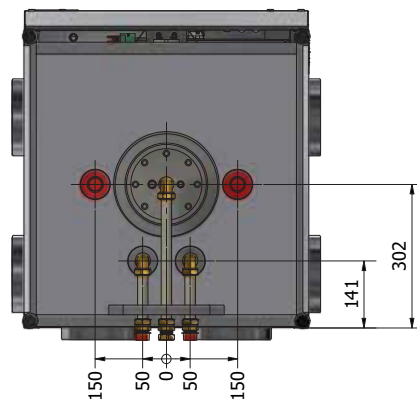

System seen from below

Temperature efficiency

"Dry" temperature efficiency according to EN 13141-7 at equal airflow on the supply and exhaust air side. This does not take into account any ice that may accumulate on the heat exchanger at low outdoor temperatures.

Temperature efficiency in accordance with EN13141-7

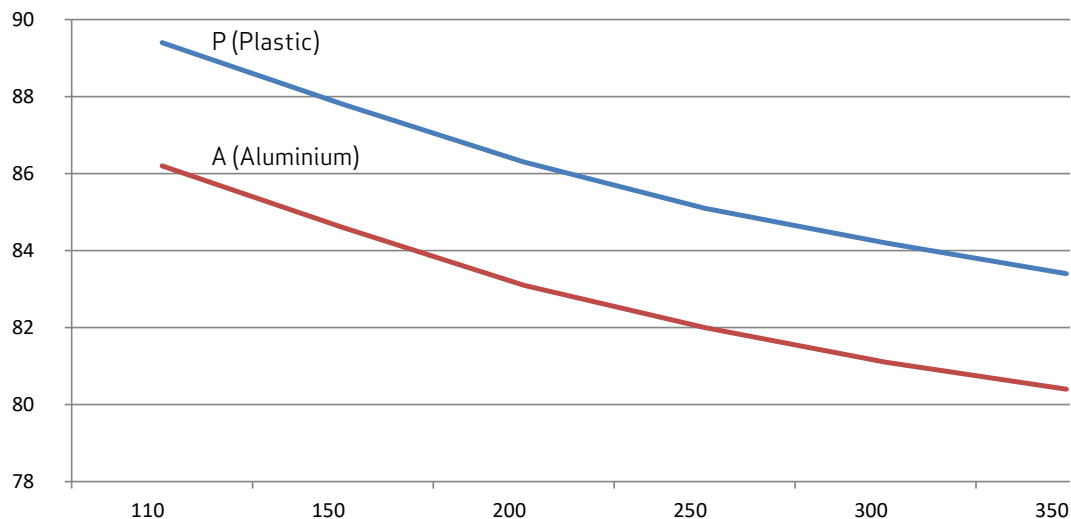

Combi Flex air heating capacity

Airflow: 160 m³/h

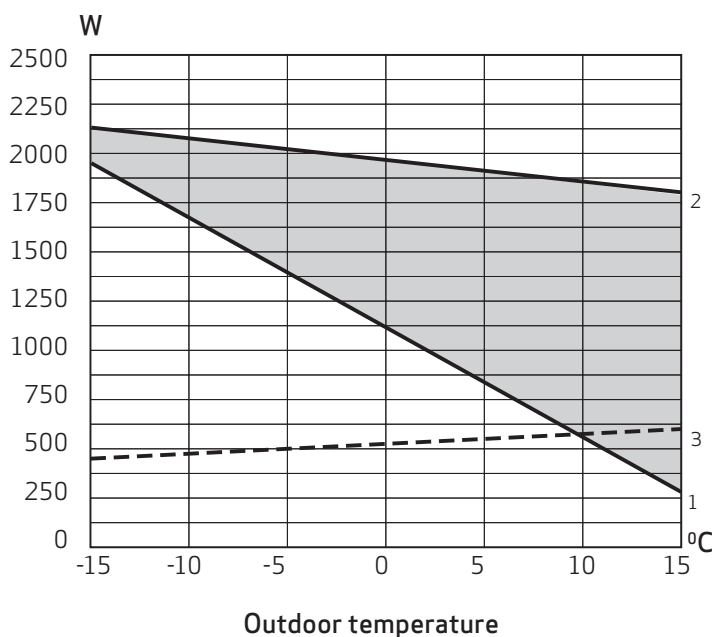

1. Energy consumption for heating the outdoor air to room temperature of 20°C.
2. Total capacity of the unit.
3. Input power with compressor.

The shaded area shows Combi Flex's contribution to space heating.

Technical specifications

COMBI FLEX

Electrical connection	
Without electric heating surface	1 x 230VAC + PE + 10 A, 50 Hz
With electric heating surface (max. 1.2 kW)	1 x 230VAC + PE + 16 A, 50 Hz
Fans with directly coupled motor	Ø180 mm backward curved blades
Motor	EC motor with integrated electronic commutation
Insulation class	B
Fan protection class	IP 54
Motor data (max. per motor)	3570 revolutions per minute
Input power (max. per motor)	90 W
Power consumption (max. per motor)	0.9A
Heat pump's working range	-15°/+35°C
Min. airflow	150 m ³ /h
Input power (max)	585W
Power consumption (max)	3.14 A
Average performance	1365 W
Average input power	425W
Refrigerant	R134a
Filling	1 000 g
Main dimensions: (h x l x d)	2 062 x 600 x 664 mm.
Cabinet construction	Double-encapsulated hot-dip galvanised plate with 30 mm insulation and tank with PU foam. Exterior powder coating white RAL 9010.
Duct connection	Ø160 mm (nipple dimensions) with rubber ring gasket
Front door	6 mm screws (2 screws for the filter lid)
Counterflow heat exchanger	Seawater-resistant aluminium
Condensate tray	Stainless steel
Condensate drain	Plastic hose Ø15 mm (inner)
Tank protection	Enamelled inside and with magnesium anode
Heating coil protection	Enamelled exterior
Filters	Supply air: G4/Coarse – Exhaust air: G4/Coarse (option F7/ ePM1)
Weight without/with water	210/395 kg

Flow Diagram

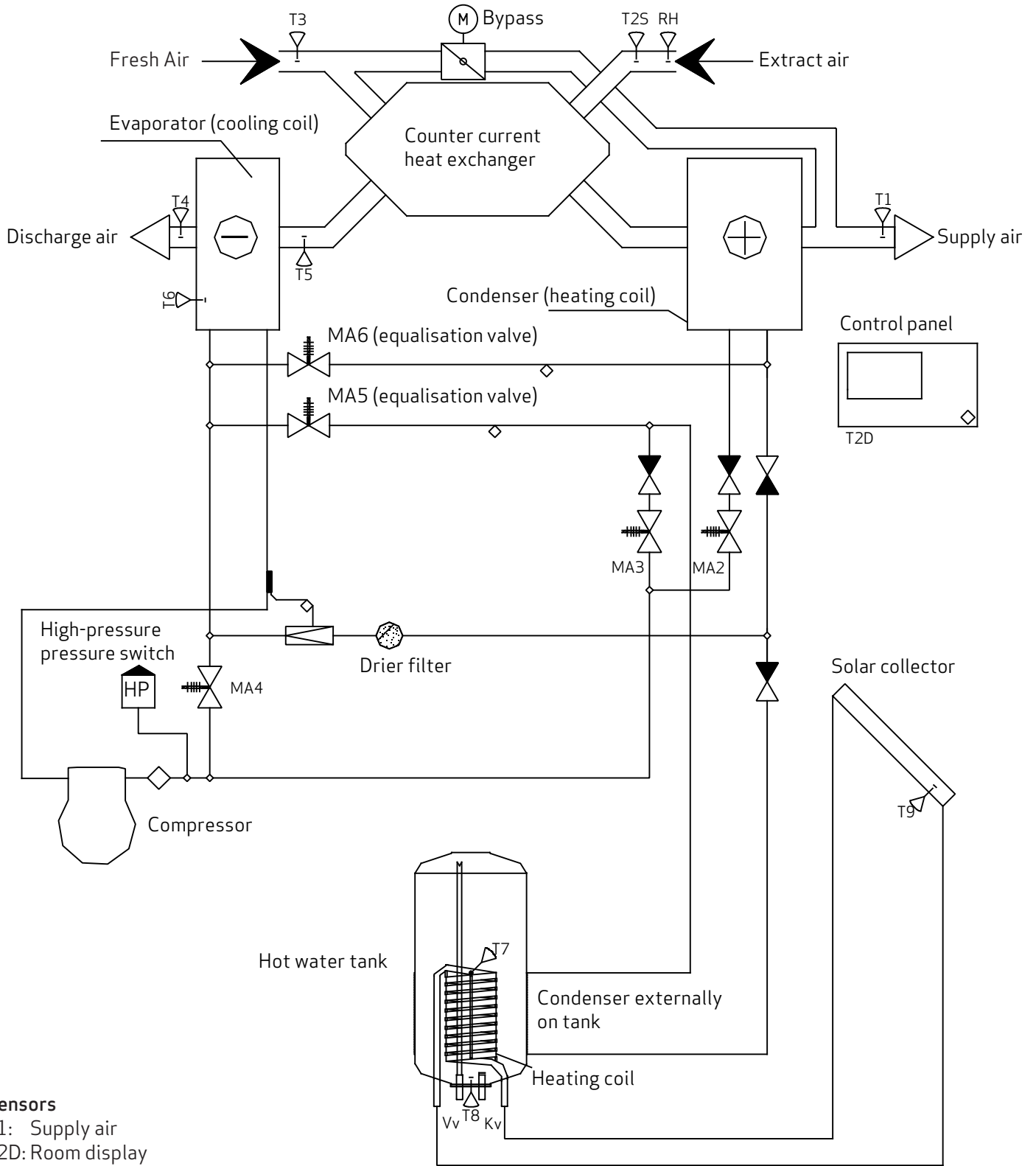

Sensors

- T1: Supply air
- T2D: Room display
- T2S: Extract air
- T3: Fresh Air
- T4: Discharge air
- T5: Before cooling coil
- T6: Cooling coil
- T7: Tank, top
- T8: Tank, bottom
- T9: Solar collector
- RH: Humidity sensor
(Only for Combi Flex)

Solenoid valves

- MA2: Roomheating
- MA3: Domestic hotwater heating
- MA4: Defrost evaporator
- MA5: purge valve (roomheating)
- MA6: purge valve (DHW)

Capacity - ventilation

The capacity lines are based on an average value of the supply and exhaust air volume in a unit. The graphs indicate the average external pressure available at a given airflow. SFP curves are reduced by 10 Pa when using a PET exchanger. (Power consumption for the controller is not included in the SFP value (approx. 6 Watt).

SFP factors COMBI Flex - measured according to EN13141-7 (G4/Coarse:Aluminium)

SFP is measured with condenser and evaporator mounted in the unit

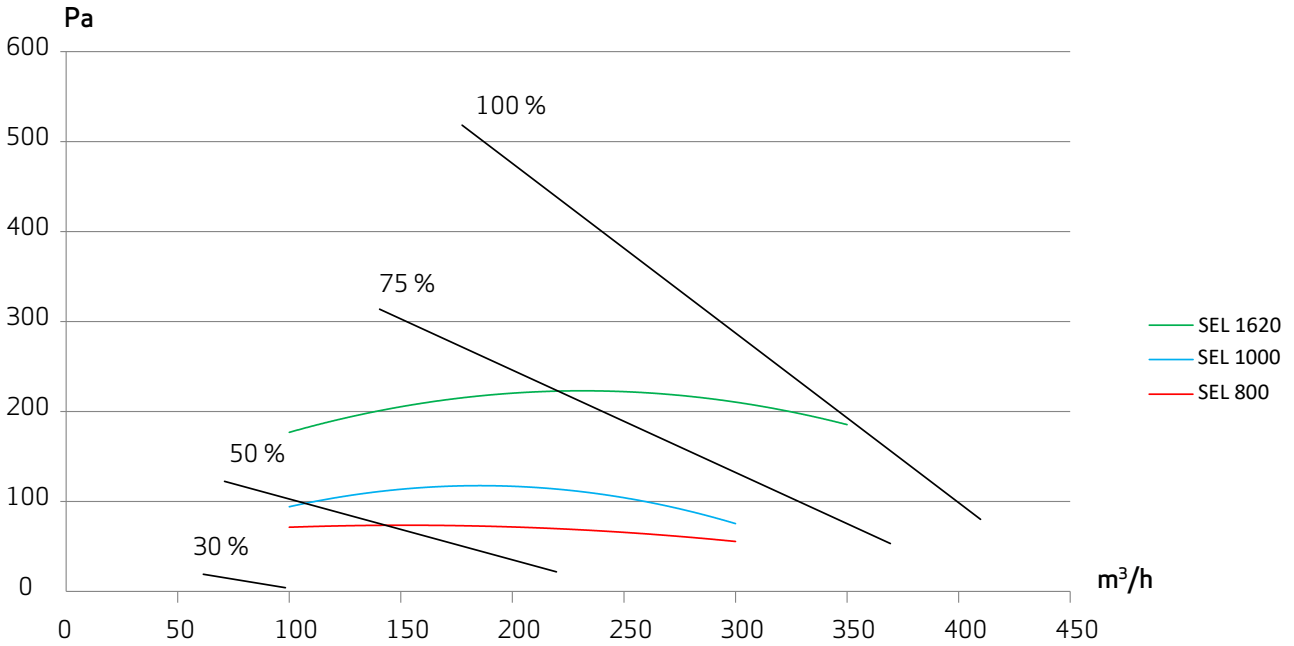

Power consumption

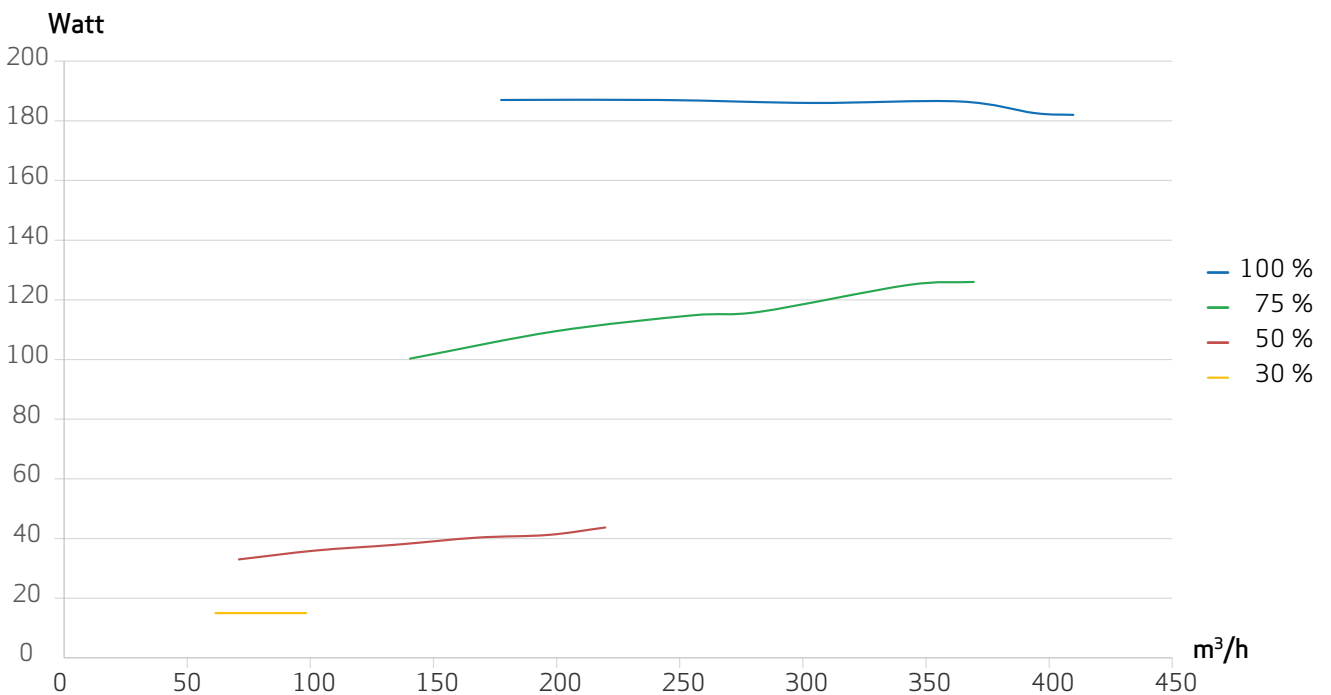

Noise data

Measuring point	1 m in front of the unit			Exhaust air duct			Supply air duct			
	Airflow	1	2	3	1	2	3	1	2	3
		Lo dB			Lwu dB			Lwi dB		
63 Hz	48	48	48	81	88	89	73	78	79	
125 Hz	49	50	51	84	85	86	75	79	79	
250 Hz	43	43	43	72	82	82	66	76	76	
500 Hz	32	32	36	60	70	73	62	66	66	
1000 Hz	23	24	25	55	63	65	51	55	57	
2000 Hz	21	21	23	52	61	62	43	51	53	
4000 Hz	-	-	-	40	54	58	43	44	46	
8000 Hz	-	-	-	29	44	46	41	42	42	
Total (A-weighted)		Lo dB(A)			Lwu dB(A)			Lwi dB(A)		
	36	37	38	67	75	77	63	68	70	

1. Measured at 40% of max speed with compressor in operation
2. Measured at 70% of max speed with compressor in operation
3. Measured at 100% of max speed with compressor in operation

Controller

Combi 185 is shipped with a complete Optima 312 controller. Optima 312 is set to factory setting, which means that the installation is ready to run without setting up the operating menu. The factory setting is only a basic setting which should be changed to the individual operational needs and requirements of each individual dwelling.

Control panel - Optima Touch

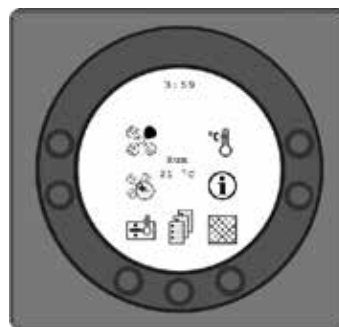

Speed (1)

This feature makes it possible to set the fan speed to levels 0 - 1 - 2 - 3 - 4.



Extended operation (2)

This feature makes it possible to set the timer for forced operation from 0 to 9 hours.



Immersion heater (3)

This feature makes it possible to turn the additional immersion heater in the hot water tank on and off.



Main menu (4)

This feature makes it possible to enter the main menu and to access the subheadings available there.



Filter (5)

This feature makes it possible to reset the litre alarm.



Information (6)

This feature makes it possible to get a good overview of the installation's current operating condition.



Temperature (7)

This feature makes it possible to set the temperature.

Contact us

